



Graver Technologies

Filtration | Separation | Purification

LPF Series Multi-Cartridge Filter Housings

High Quality Multi-Cartridge Filter Housings

LPF Series filter housings are constructed of durable stainless steel and meet general purpose industrial and commercial filtration needs. All wetted welded surfaces are stainless steel. External surfaces are bead blasted for a consistent, easy care finish.

Applications

- Potable water
- Edible oils
- Cutting oils
- Process water
- Lubricants
- Solvents
- Coatings
- Coolants

Housing Features

- Durable 304L or 316L stainless steel for excellent corrosion resistance
- Universal seat cups accept DOE or 222 style filters; 226 cups optional
- Choice of V-band clamp or swing bolts for convenient cartridge change outs
- Eye nuts on swing bolt style facilitate removal with minimal tools
- Accepts 10", 20", 30" and 40" cartridges
- Fully threaded tie rod allows for fitment of various style/lengths of filters; wing nut for ease of removal
- Removable cartridge posts for easy cleanouts
- Suitable for flow rates from 21 to 588 GPM
- Accommodates up to 2³/₄" OD cartridges
- Equipped with 1/4" vent and 1/2" drain

Available Options

- 150lb ANSI raised face flange
- Various MNPT Inlet/Outlet sizes
- Legs for maximum stability (standard for LPF 7 and up)
- Mounting tabs (option for LPF 3 and LPF 5)
- 226 configuration
- Gauge ports
- Hinge or davit arm optional on 21 around

Housing Specifications

Maximum Operating Pressure:

150 psig (10.3 bar) @ 200°F in liquid service
Not for use with compressed gases

Shell O-Ring:

Buna N, Viton, EPDM, Teflon encapsulated Viton

Internal Components:

316L compression plate and tie rod are included for use with single open end filters. If double open end filters will be used, specify IP (internal parts) in the housing description to obtain tube guides and springs.



LPF SERIES MULTI-CARTRIDGE FILTER HOUSINGS

SWING BOLT DESIGN

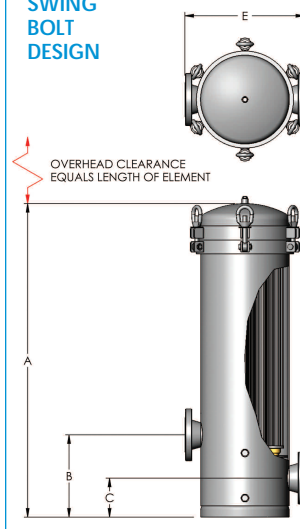

V-BAND DESIGN

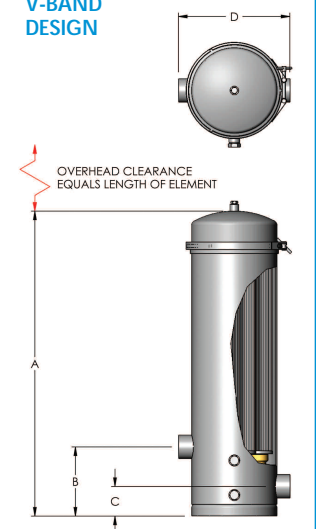

LPF Series Housing Dimensional Data

Model	Rated Flow Capacity ³	No. 10" Elements	Dim. "A" inches (cm)	Dim. "B" inches (cm)	Dim. "C" inches (cm)	Dim. "D" ¹ inches (cm)	Dim. "E" ¹ inches (cm)	Std. Conn. size/type	Drain	Vent
LPF 03-1	21 (79)	3	20 7/8" (53)	7" (17.8)	3" (7.6)	9 1/2" (24.1)	10 5/8" (27)	1 1/2" MNPT	1/2" NPT	1/4" NPT
LPF 03-2	42 (159)	6	30 7/8" (78.4)	7" (17.8)	3" (7.6)	9 1/2" (24.1)	10 5/8" (27)	1 1/2" MNPT	1/2" NPT	1/4" NPT
LPF 03-3	63 (238)	9	40 7/8" (12.4)	7" (17.8)	3" (7.6)	9 1/2" (24.1)	10 5/8" (27)	1 1/2" MNPT	1/2" NPT	1/4" NPT
LPF 03-4	84 (318)	12	50 7/8" (129.2)	7" (17.8)	3" (7.6)	9 1/2" (24.1)	10 5/8" (27)	1 1/2" MNPT	1/2" NPT	1/4" NPT
LPF 05-1	35 (132)	5	20 7/8" (53)	7" (17.8)	3" (7.6)	11 1/4" (28.6)	12 3/4" (32.4)	2" MNPT	1/2" NPT	1/4" NPT
LPF 05-2	70 (265)	10	30 7/8" (78.4)	7" (17.8)	3" (7.6)	11 1/4" (28.6)	12 3/4" (32.4)	2" MNPT	1/2" NPT	1/4" NPT
LPF 05-3	105 (398)	15	40 7/8" (12.4)	7" (17.8)	3" (7.6)	11 1/4" (28.6)	12 3/4" (32.4)	2" MNPT	1/2" NPT	1/4" NPT
LPF 05-4	140 (530)	20	50 7/8" (129.2)	7" (17.8)	3" (7.6)	11 1/4" (28.6)	12 3/4" (32.4)	2" MNPT	1/2" NPT	1/4" NPT
LPF 07-1	49 (185)	7	28 3/4" ² (73.0)	16" ² (40.6)	9 3/4" ² (24.8)	13 1/2" (34.3)	14 3/4" (37.5)	2" MNPT	1/2" NPT	1/4" NPT
LPF 07-2	98 (371)	14	38 3/4" ² (98.4)	16" ² (40.6)	9 3/4" ² (24.8)	13 1/2" (34.3)	14 3/4" (37.5)	2" MNPT	1/2" NPT	1/4" NPT
LPF 07-3	147 (557)	21	48 3/4" ² (123.8)	16" ² (40.6)	9 3/4" ² (24.8)	13 1/2" (34.3)	14 3/4" (37.5)	2" MNPT	1/2" NPT	1/4" NPT
LPF 07-4	196 (742)	28	58 3/4" ² (149.2)	16" ² (40.6)	9 3/4" ² (24.8)	13 1/2" (34.3)	14 3/4" (37.5)	2" MNPT	1/2" NPT	1/4" NPT
LPF 12-2	168 (636)	24	39 3/8" ² (97.5)	16" ² (40.6)	9 3/4" ² (24.8)	17 1/4" (43.8)	17 1/4" (43.8)	3"-150# flange	1/2" NPT	1/4" NPT
LPF 12-3	252 (954)	36	49 3/8" ² (125.4)	16" ² (40.6)	9 3/4" ² (24.8)	17 1/4" (43.8)	17 1/4" (43.8)	3"-150# flange	1/2" NPT	1/4" NPT
LPF 12-4	336 (1272)	48	59 3/8" ² (150.8)	16" ² (40.6)	9 3/4" ² (24.8)	17 1/4" (43.8)	17 1/4" (43.8)	3"-150# flange	1/2" NPT	1/4" NPT
LPF 21-3	441 (1669)	63	49 3/8" ² (125.4)	16" ² (40.6)	9 3/4" ² (24.8)	21 5/8" (54.9)	21 5/8" (54.9)	4"-150# flange	1/2" NPT	1/4" NPT
LPF 21-4	588 (2226)	84	59 3/8" ² (150.8)	16" ² (40.6)	9 3/4" ² (24.8)	21 5/8" (54.9)	21 5/8" (54.9)	4"-150# flange	1/2" NPT	1/4" NPT

Notes:

1. Dimensions are based on the standard connection sizes.
2. Dimensions include support legs.
3. Flow capacity based on pleated filters rated at 7GPM per 10" equivalent. Actual flow rate is dependant upon cartridge type and application.

LPF Series Housing Nomenclature Information

LPF	03	R	2	-N	2	-U	-VB	-E	-GPX-T-IP
Model	# of Filters	Material of Construction	Cartridge Height (10" Lengths)	Inlet/Outlet	Inlet/Outlet Size (inches)	Seat Cup Style	Closure Type	Gasket	Options
LPF Series	03=3 around 05=5 around 07=7 around 12=12 around 21=21 around	R=304L SS T=316L SS	1 2 3 4	N - NPT F - Flange	1.5 2 3 4	U=Universal (DOE or 222) X=226	VB - V Band SB - Swing Bolts	B - Buna-N E - EPDM T - Te on V - Viton	T - Tabs L - Legs GPX - Gauge Port GPG - Gauge Port and Gauge IP - Internal parts (tube guides and springs) H - Hinge DA - Davit Arm

Example: LPF03R2-N2-U-VB-E-GPX-T-IP

All information and recommendations appearing in this bulletin concerning the use of products described herein are based on tests believed to be reliable. However, it is the user's responsibility to determine the suitability for his own use of such products. Since the actual use by others is beyond our control, no guarantee, expressed or implied, is made by Graver Technologies as to the effects of such use or the results to be obtained. Graver Technologies assumes no liability arising out of the use by others of such products. Nor is the information herein to be construed as absolutely complete, since additional information may be necessary or desirable when particular or exceptional conditions or circumstances exist or because of applicable laws or government regulations. LPF is a trademark of Graver Technologies.

For more information

Graver Technologies Customer Service: **1-888-353-0303**
 Technical Support: **1-800-510-0932**
 E-mail us at info@gravertech.com

DISTRIBUTED BY:



200 Lake Drive
Glasgow,
DE 19702 U.S.A.

302- 731-1700
800- 249-1990
Fax 302-369-0938

e-mail: info@gravertech.com
web site: www.gravertech.com

