



Part Number: NPS4BGB  
Version: D.1



## GAS DETECTION

We are delighted that you have chosen an **OLDHAM** instrument and would like to thank you for your choice.

We have taken all the necessary measures to ensure that your instrument provides total satisfaction in the future.

Now it is important to read this document carefully.

### EXTENT OF RESPONSIBILITY

- \* **OLDHAM** declines its responsibility towards any person for material damage, physical injury or death resulting wholly or partly from inappropriate use, installation or storage of its equipment resulting from failure to observe instructions and warnings and/or standards and regulations in force.
- \* **OLDHAM** neither supports nor authorises any company, physical or moral person to assume responsibility on behalf of **OLDHAM**, even if it is involved in the sale of **OLDHAM** products.
- \* **OLDHAM** cannot be held responsible for direct or indirect damage or be required to pay direct or indirect compensation resulting from the sale or use of any of its products **IF THESE PRODUCTS HAVE NOT BEEN DEFINED AND CHOSEN BY OLDHAM FOR THEIR SPECIFIC USE.**

### CLAUSES CONCERNING PROPERTY

- \* Drawings, plans, specifications and information included in this document contain confidential information that is the property of **OLDHAM**.
- \* None of this information may be reproduced, copied, divulged or translated, by physical, electronic or any other means, nor used as the basis for the manufacture or sale of **OLDHAM** equipment or for any other reasons **without prior consent from OLDHAM.**

### WARNINGS

- \* This document is not contractually binding. In the interests of its customers, **OLDHAM** reserves to modify the technical specifications of its equipment without notice, in order to improve its performance.
- \* **READ THIS MANUAL CAREFULLY BEFORE FIRST USE OF THE EQUIPMENT:** this manual must be read by any person who is or will be responsible for using, maintaining or repairing this equipment.
- \* **This equipment will only provide the announced performance levels if it is used, maintained and repaired according to OLDHAM directives, by OLDHAM personnel or by personnel approved by OLDHAM.**

### GUARANTEE

2 years guarantee in normal conditions of use on parts and technical labour, return in our workshops, excluding consumables (sensors, filters, etc.).

## Warnings

This manual must be read carefully before installing and starting up and, in particular, care must be taken to observe the points concerning the safety of the equipment for intermediate or end users.

Installation must be performed and electrical connections made by qualified personnel in accordance with the manufacturer's instructions and with the standards specified by the relevant authorities.

Failure to comply with instructions can have serious consequences for the safety of personnel. An absolutely rigorous approach is required, especially as concerns electricity and fitting (connections and connection to the power network).

Any modification of the equipment or the use of parts not specified as original manufacturer's parts could lead to the cancellation of any form of warranty.

The data logger is intended to be used for one or more applications specified in the technical characteristics.

The values indicated must not be exceeded in any circumstances.

This is not a contractually binding document. In the interest of its customers, OLDHAM reserves the right to make any changes, without notice, to the technical characteristics of its equipment in order to improve performance levels.

## Warning signs



**Protective earth terminal**



**Caution: risk of electric shocks**



**Caution (See accompanying documents)**

# Contents

<b>I. DESCRIPTION</b>	<b>7</b>
<b>II. MOUNTING OF THE SURVEYOR 4B</b>	<b>7</b>
<b>III. CONNECTIONS</b>	<b>9</b>
3.1. Alternative power supply	9
3.2. DC power supply	9
3.3. Explosimetric detectors	10
3.4. External components	10
3.5. Examples of installation	11
<b>IV. OPERATING INSTRUCTIONS</b>	<b>12</b>
4.1. Switching on	13
4.2. Switching off	13
4.3. Alarms	13
4.3.1. GAS alarm	13
4.3.2. FAULT alarms	14
4.4. Adjustments	14
4.4.1. Adjusting the "gas alarm" thresholds	15
4.4.2. Acknowledgement of gas alarms	16
4.4.3. Adjusting the ZERO	17
4.4.4. Checking the sensitivity	17
4.5. Replacing the fuse	19
<b>V. TECHNICAL SPECIFICATIONS</b>	<b>21</b>
<b>VI. DISPOSAL</b>	<b>21</b>
<b>VII. EU DECLARATION OF CONFORMITY</b>	<b>22</b>



## I. DESCRIPTION

Surveyor 4B is equipped with a small "NORMAL" box (58 x 105 x 90 mm). It can be snap-fastened onto a standard symmetrical DIN rail and is easily integrated in an electric equipment cabinet.

The components used in operation are located on the front of the appliance:

- adjustments and tests on the top (item 1),
- indicator lights on the FRONT face (item 2),
- connections at the bottom (item 3).

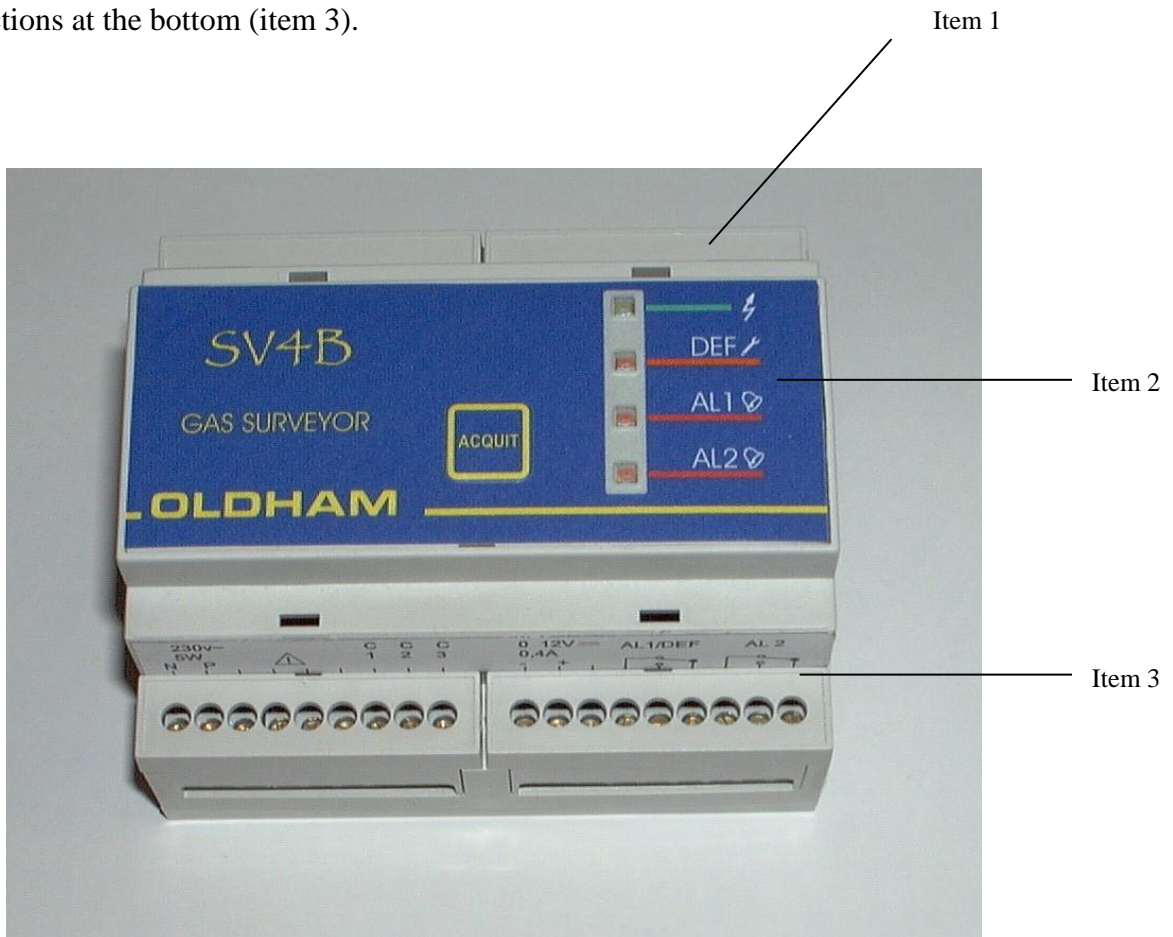

**FIGURE 1**

## II. MOUNTING OF THE SURVEYOR 4B

The surveyor 4B appliance fitted on its symmetrical DIN rail can be installed in a box in any electrical equipment cabinet and has no special installation requirements.

The Surveyor 4B can be installed in safe area only.

It should preferably be located in a monitored location (such as a guardhouse, control room or instrumentation room).





### III. CONNECTIONS

Electrical connections must be made by a specialist and must comply with the regulations in force. They must also be in conformance with standard NF C 15-100.

The nature of the current and line voltage must be checked. The line voltage must match the voltage specified on the plate fitted on the Surveyor 4B. The voltage is configured in the factory.

The wires to be connected to the Surveyor 4B must have a minimum cross section of 1.5 mm<sup>2</sup>.

The Surveyor 4B appliance can be supplied with either 230 VAC<sup>1</sup> or 12 VCC<sup>2</sup>.

#### 3.1. Alternative power supply

##### 230 volt AC power supply

The Surveyor 4B must be protected on the upstream side by a two-pole earth leakage circuit breaker (1A).

The response curve must be of type D.

The mains power supply must be wired on the two points marked N (Neutral) and P (Phase) on the Surveyor 4B terminal block (see Fig 2, item 1).

Power consumption: 5 VA max. (detector connected).

#### 3.2. DC power supply

##### 12-volt power supply

The 12 volt power supply can be connected to the points marked 0 and 12 V on the Surveyor 4B terminal block (see Fig. 2, item 2).

The cable must have a minimum cross section of 1.5 mm<sup>2</sup>.

Power consumption: 4 W max. (detector connected).

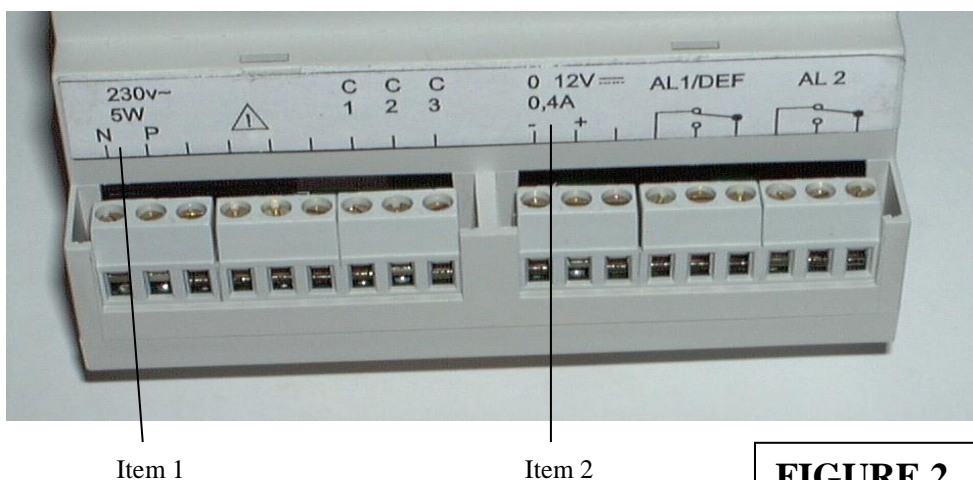

**FIGURE 2**

<sup>1</sup> From 207 to 242 V AC

<sup>2</sup> From 11.5 to 14 V DC

### 3.3. Explosimetric detectors

- Only explosimetric detectors of the "bridge" type can be connected to the SV 4B.
- Surveyor 4B and the detector are connected together by a shielded cable with three active conductors. The shielded cable is to be connected to the earth at one end only.
- Terminals C1, C2 and C3 of Surveyor 4B and the detector are to be connected in opposite mode (see Fig. 3).

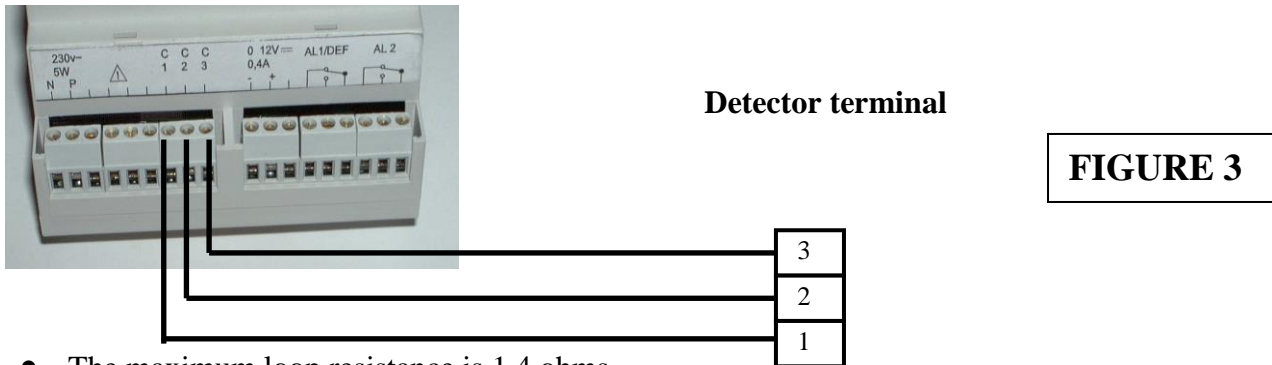

- The maximum loop resistance is 1.4 ohms.  
For example: the maximum distance between Surveyor 4B and the detector will be 40 m with conductors with a cross section of 1.5 mm<sup>2</sup>.

### 3.4. External components

Surveyor 4B is equipped with the following two relays.

- Relay 1 (REL 1), which is in mode, corresponds to the first gas alarm threshold and to the "FAULT" alarm.  
This relay is equipped with SPDT contacts available on the SV 4B terminal block (item 3, Fig. 5).
- Relay 2 (REL 2), which is "negative safety" mode, corresponds to the second gas threshold only. This relay is also equipped with SPDT contacts available on the SV 4B terminal block (item 4, Fig. 5).
- These both relays could be configured in positive and negative security (programming by welding slots on the printed circuit board: made only by OLDHAM or a skilled personal).

**FIGURE 5**

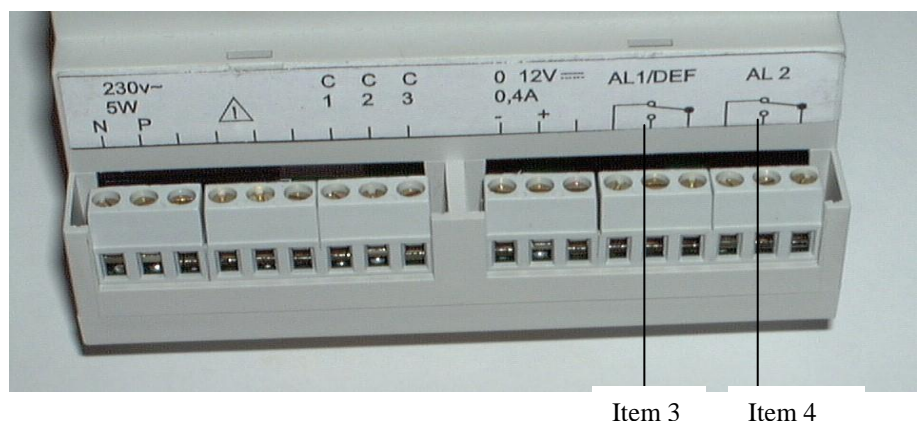

NB: The relay contacts are dry contacts, corresponding to the appliance without power supply.  
Caution: The high-power solenoid valves cannot be directly remote controlled<sup>3</sup>. A power relay is required.

<sup>3</sup> The maximum current through the relay contacts will be 2 A and the maximum voltage will be 240 V ~ or 60 V - - -.

### 3.5. Examples of installation

#### Example of installation set up of a SV 4B with TWO OLC 10 TWIN detectors

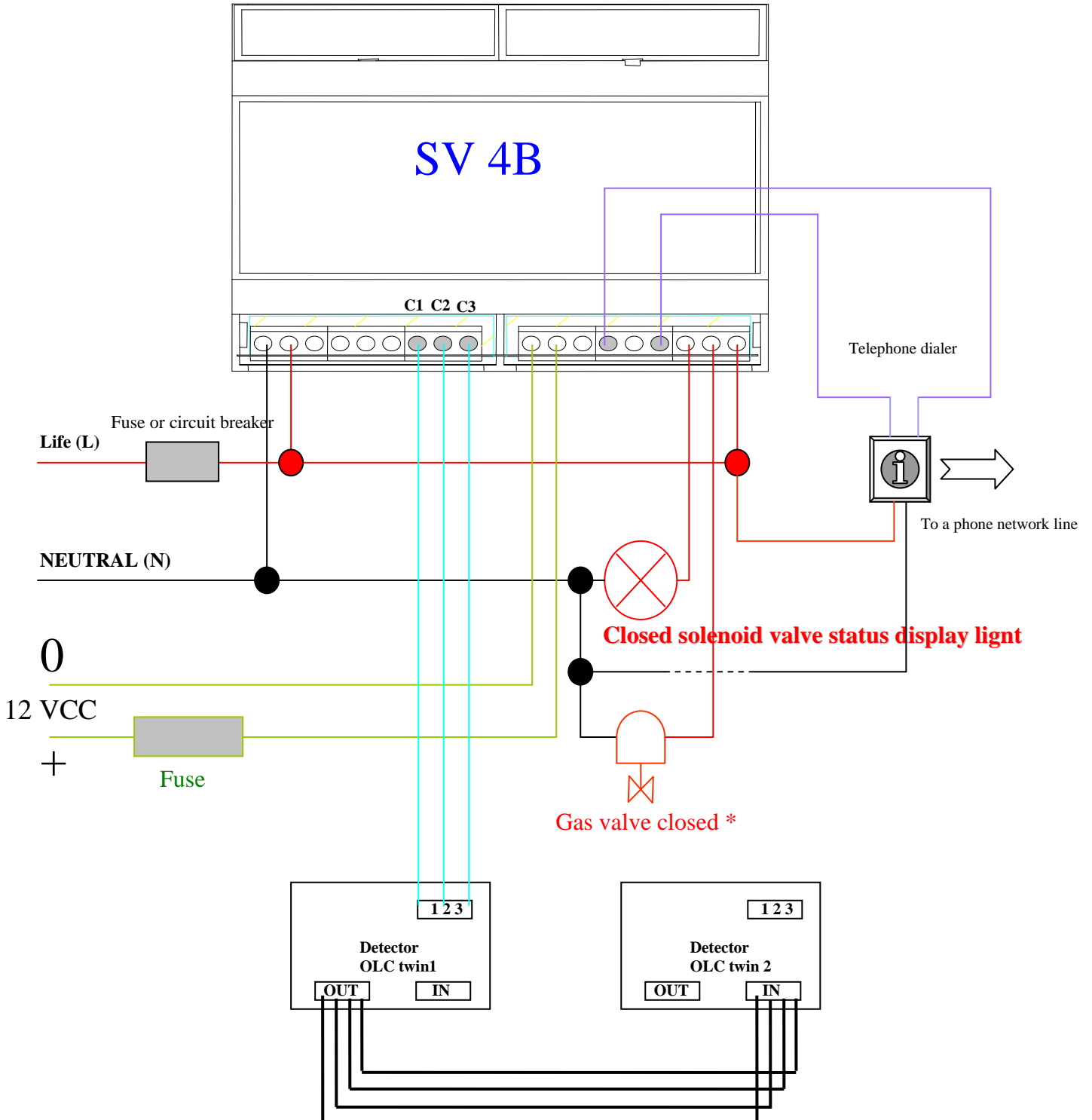

\* Breaking capacity of rating relays switch contact : 2A / 250Vca – 30Vcc

#### **Important:**

The relay's contacts are shown on the SV 4B label, unit switch off.

The AL1/ DEF relays are normally energized and the AL2 relay is unenergized.

## Example of installation set up of a SV 4B with a single detector.

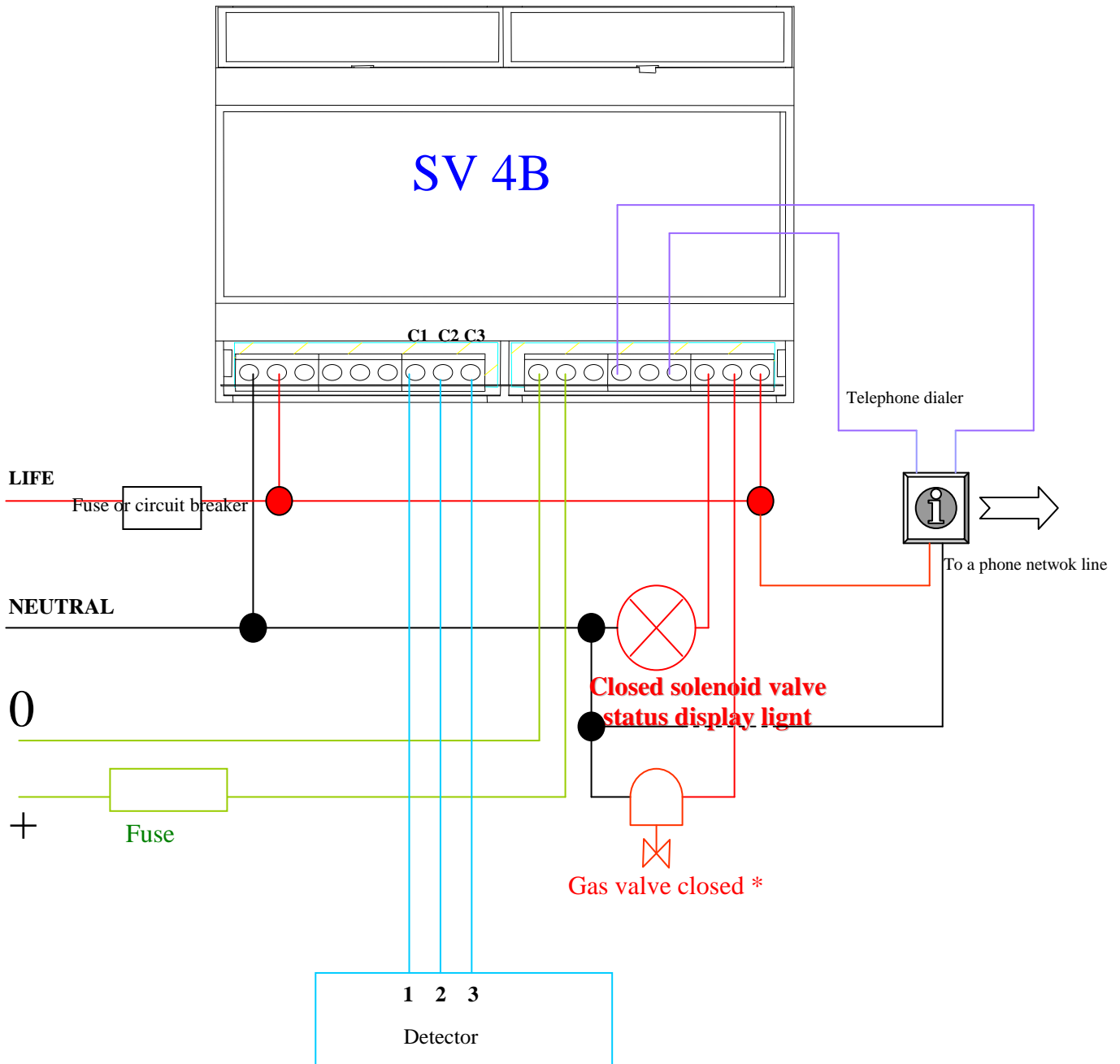

\* Breaking capacity of rating relays switch contact : 2A / 250Vca – 30Vcc

**Important:**

The relay's contacts are shown on the SV 4B label, unit switch off.  
The AL1/ DEF relays are normally energized and the AL2 relay is unenergized.

## IV. OPERATING INSTRUCTIONS

### 4.1. Switching on

It is assumed that all the necessary connections have been made and that the whole installation complies with the standards currently in force.

As soon as the SV 4B is supplied with power, it is ready to use and the GREEN light-emitting diode lights up (item 1, Fig. 6).

Relay 1 is operated ("positive safety" position).

### 4.2. Switching off

The SV 4B is switched off by cutting off the power supply on an electrical equipment cabinet.

### 4.3. Alarms

#### 4.3.1. GAS alarm

The SV 4B has two adjustable GAS alarm thresholds but the second threshold (AL 2) must be twice the first (AL 1).

Therefore, the red light-emitting diodes "AL1" and "AL2" (item 3, Fig. 6) come on as soon as the alarm thresholds are exceeded (time delay of 7 seconds): LED flashing. The audio alarm (buzzer) is activated and the corresponding relays are tripped.

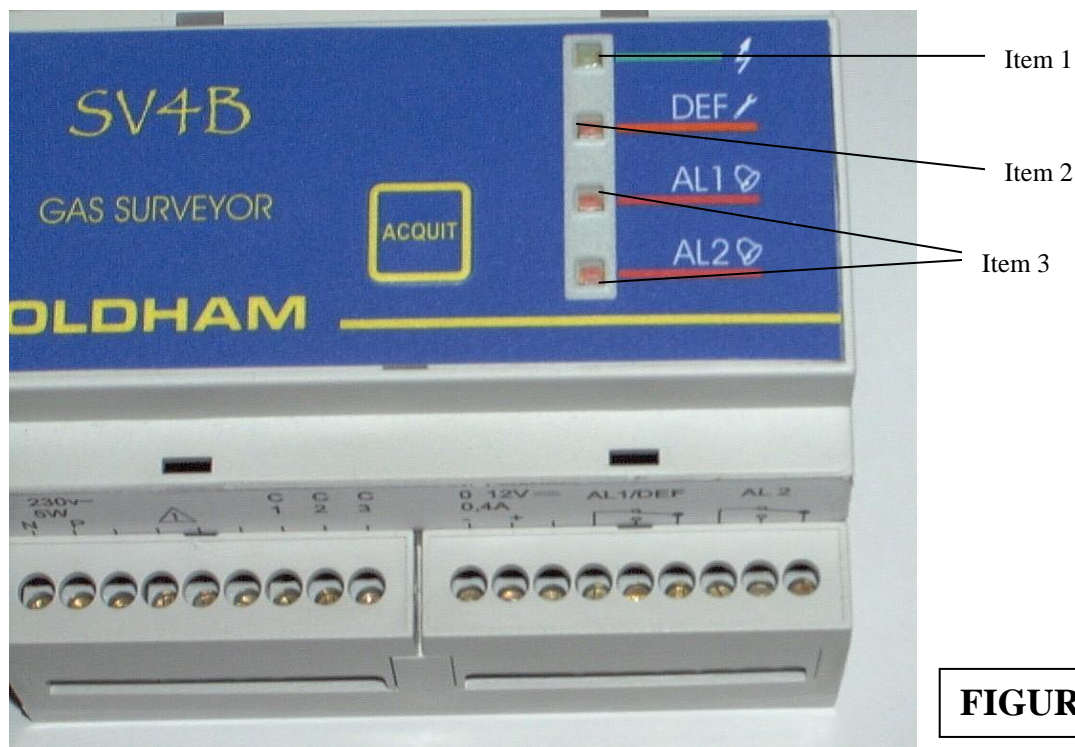

**FIGURE 6**

### 4.3.2. FAULT alarms

The SV 4B is equipped with a fault alarm (visual alarm (item 2, Fig. 6), audio alarm and relay 1) which is activated in the following cases:

- One or more wires of the telemetry line interrupted,
- One or more wires of the telemetry line short-circuited or with excessive power consumption.

**NB: The ALARM LEDs may also be activated depending on the circumstances of the interruption or the short circuit.**

## 4.4. Adjustments

Caution: The operations and adjustments described in this chapter must be performed by authorized personnel only as they can affect the appliance's reliability in detection.

Gas detection instruments are potential life-saving devices. Recognizing this fact, OLDHAM Corporation recommends that a functional “bump” test be performed on every fixed gas-monitoring instruments as part of a regular maintenance program. A functional test is defined as a brief exposure of the detector to a concentration of gas(es) in excess of the lowest alarm set-point for each sensor for the purpose of verifying sensor and alarm operation and is not intended to be a measure of the accuracy of the instrument.

OLDHAM further recommends that a full instrument calibration be performed using a certified concentration(s) of calibration gas(es) quarterly, every 3 months.\* Calibrations may be necessary more or less frequently based, for example, on application, field conditions, exposure to gas, sensor technology, and environmental conditions. The frequency of calibration is best determined by company policy or local regulatory agencies.

If an instrument fails to operate properly during any functional “bump” test, a full instrument calibration should be performed successfully prior to use.

These recommendations are based on safe work procedures, industry best practises, and regulatory standards to ensure worker safety. OLDHAM is not responsible for setting safety practices and policies.

*\* For new installations it may be prudent to carry out bump tests frequently at first (perhaps weekly), increasing the time intervals (to, perhaps, monthly or more) as confidence grows with experience in the installation concerned, on the basis of the maintenance record.*

#### 4.4.1. Adjusting the "gas alarm" thresholds

Using a "reference gas kit" (gas cylinder + pressure regulator, etc.), inject the reference gas with a content level higher than the first threshold desired. (For example, threshold 1 will be 20% LEL, so a minimum of 25% LEL should be injected).

Adjust the alarm potentiometer (item 1, Fig. 7) to trigger the first threshold (AL1): the red LED (AL1) flashes (for 7 seconds) and then remains on in steady mode, trip the corresponding alarm relay.

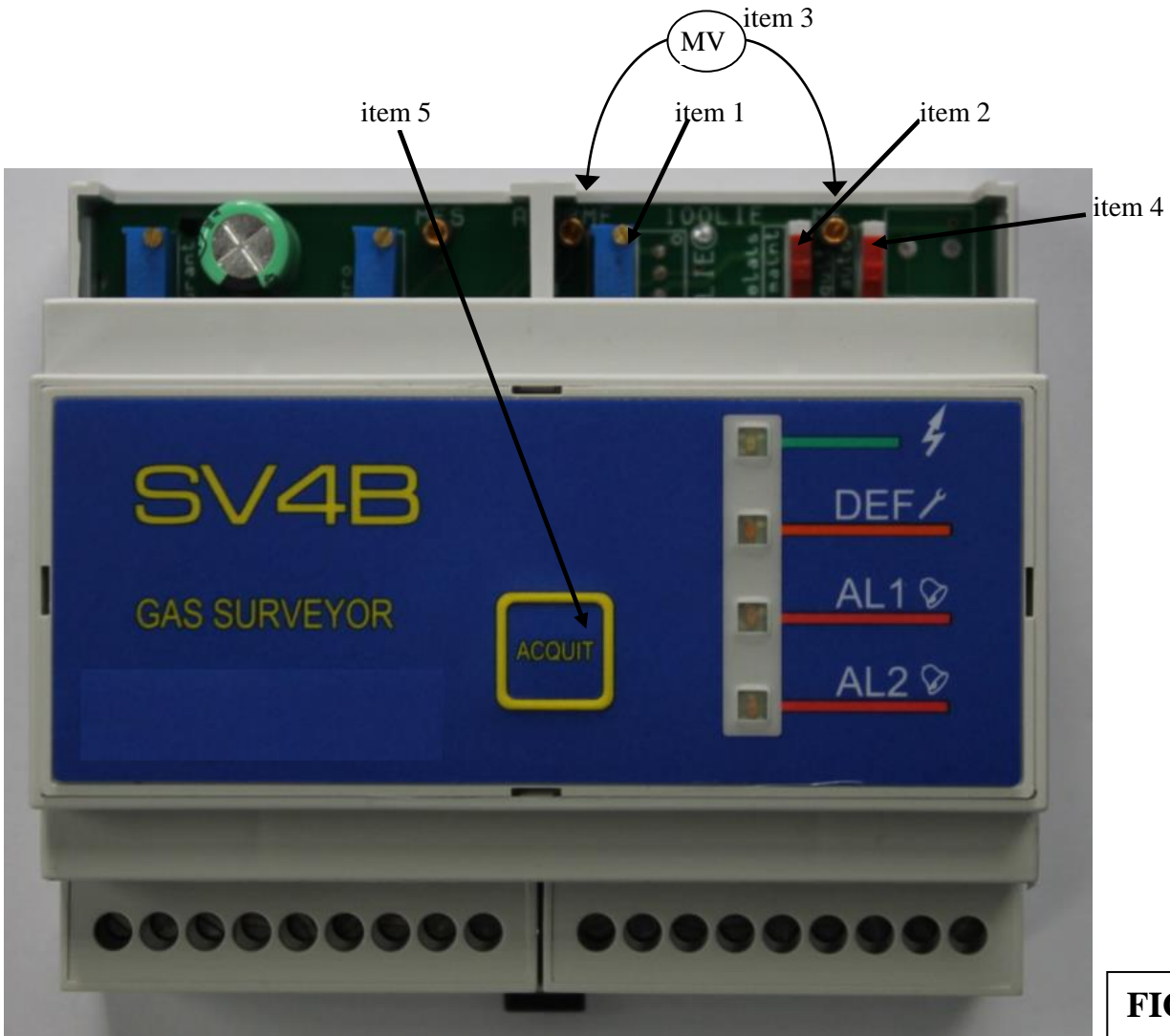
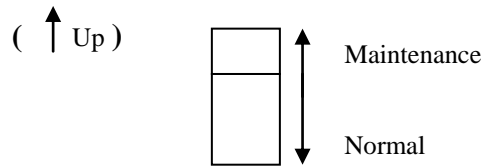

**FIGURE 7**

If you stop at this point, alarm 2 will be set to twice the level of alarm 1.

If you continue until alarm 2 is triggered: alarm 1 will be set to half the level of alarm 2.

If you wish to lock the alarm relays (inhibiting the relays) during these alarm threshold adjustments: set the maintenance switch to the high position (item 2, Fig. 7).



**Caution:** When the adjustments have been made, do not forget to place the switch back in its normal position.

Terminal posts (item 3, Fig. 7) are used to connect up a voltmeter for the reading of a signal (in mV) corresponding to the content level of the injected gas.

Then, using a rule of three, it is possible to calculate and adjust another signal (in mV) for an alarm threshold (potentiometer: item 1, Fig. 7) corresponding to a different gas content level.

For example: when you inject 1% methane, you read 1,000 mV (for instance).

If you set the alarm potentiometer to read 1,500 mV, the alarm is triggered at 1.5% methane.

$$\text{Signal} = \frac{1000mV \times 1\%}{1000mV} = 1500mV$$

Or

$$\text{Threshold (\%)} = \frac{1\% \times 1500mV}{1000mV} = 1.5\%$$

#### 4.4.2. Acknowledgement of gas alarms

A switch (item 4, Fig. 7) is used to acknowledge gas alarms in manual mode<sup>4</sup> or automatic mode<sup>5</sup>.

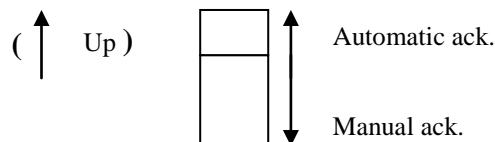

**Remark:** As long as there is a high enough concentration of gas to trigger an alarm, it is impossible to clear that alarm manually (with the Ack. button).

<sup>4</sup> Manual mode: When a gas alarm is triggered, it must be cleared manually even if the content level has fallen to zero (or to below the threshold). This is done by pressing the **Ack.** key (item 5, Fig. 7).

<sup>5</sup> Automatic mode: When a gas alarm is triggered, it is cleared automatically as soon as the content level falls below the alarm threshold.



#### 4.4.3. Adjusting the ZERO

- Necessary when a cell is replaced.
- At least twice a year.
- Connect a voltmeter to the two terminal posts provided for that purpose (MF and MES), as shown below.



**FIGURE 8**

- Be sure to be in pure atmosphere (without gas) (If not, inject air)
- Adjust the ZERO (0 mV) with the potentiometer, item 1. Figure 8

#### 4.4.4. Checking the sensitivity

- Necessary when a cell is replaced.
- At least twice a year.
- Prepare the calibration kit and secure the gas input pipe to the detector.
- Adjust the flow rate of the reference gas <sup>6</sup>(1) to 60 l/h before injecting.
- Allow to stabilize for at least 10 seconds.
- Check that the alarm or alarms are triggered (as applicable <sup>6</sup>) and carry out the following procedure.

<sup>6</sup> The value of the reference gas must be higher than at least the first alarm threshold.

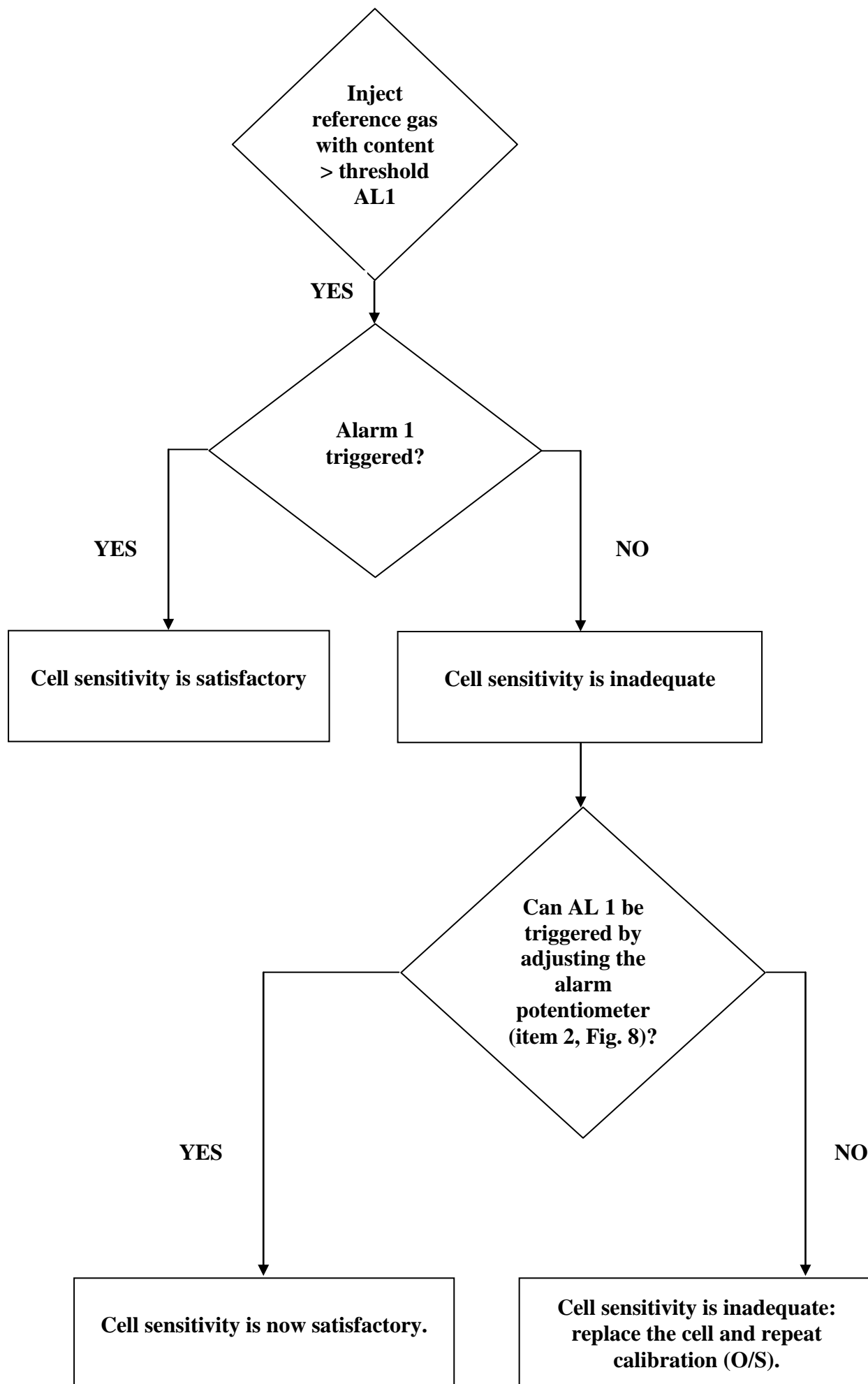

## 4.5. Replacing the fuse

**It is mandatory that spare parts must be guaranteed original OLDHAM parts as, otherwise, the reliability of the equipment could be adversely affected.**

The fuse (Fig. 9, item 1) must be replaced by qualified personnel only.

The fuse is, and must be, in compliance with CEI 127, with time-delay, low breaking capacity and a voltage of 250 V ~.

- Fuse 5x20- T125 mA 250 V- OLDHAM reference = 6154701

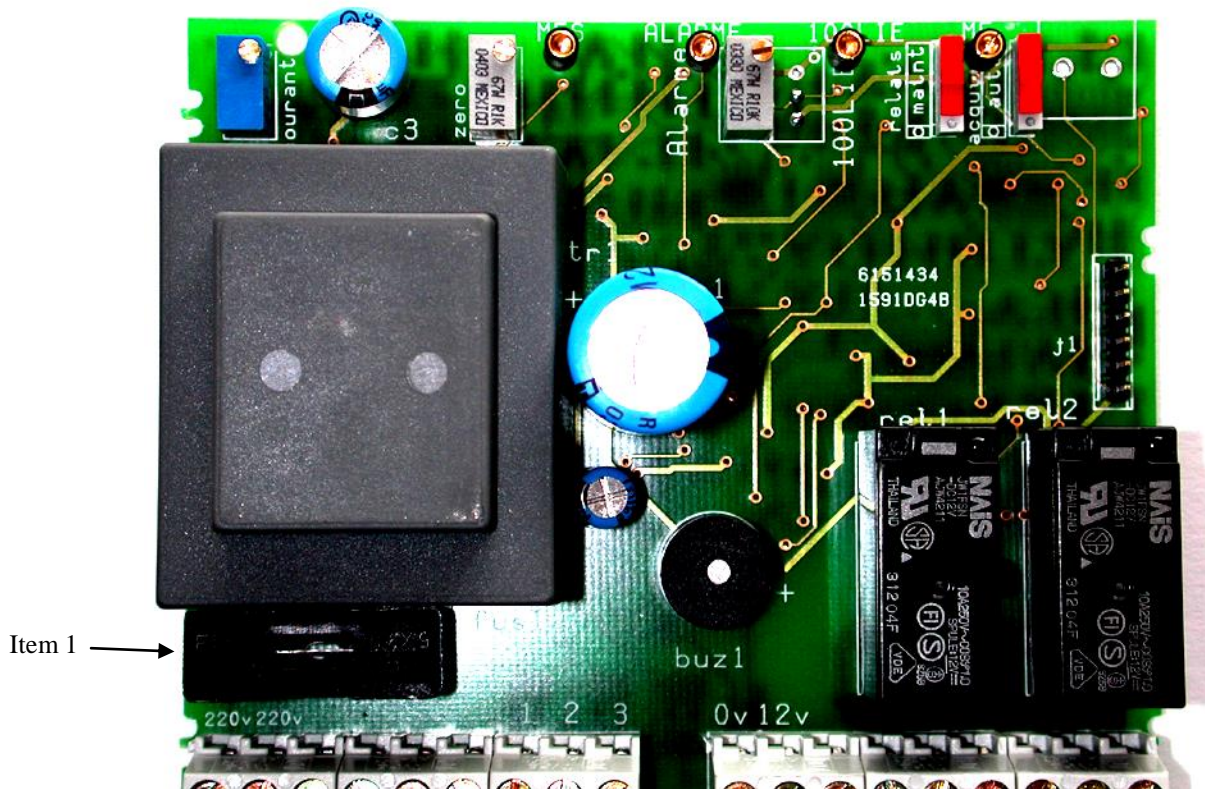

**FIGURE 9**



## V. TECHNICAL SPECIFICATIONS

Manufacturer	OLDHAM
Type	SURVEYOR 4B
Function	Control station for explosive gas detectors
Capacity	1 channel: 1 or 2 detectors
Measurement <i>Measurement</i> <i>Display unit</i>	Continuous None
Visual alarms	Failure: yellow Gas, 1st threshold: red Gas, 2nd threshold: red
Audio alarm	Integrated
Alarm Acknowledgement	Manual or automatic
Electric power supplies <i>AC</i> <i>DC</i>	230 VAC (207 to 242 V) (programmed in factory) 12 VDC (11.5 to 14 V)
Power consumption	5 VA or 4 W (detector connected)
Electrical protection	Fuse
Relays <i>Relay 1</i> <i>Relay 2</i>	Common to gas and fault Gas
Contact	SPDT, relay 1 (positive safety) SPDT, relay 2
Max. breaking capacity	60 VA or 28 W resistive
Maximum voltage	2A / 250Vca – 30Vcc
Maximum current	1 A
Measuring line <i>Cable</i> <i>Maximum line length</i> <i>Maximum loop resistance</i>	3 conductors 40 m (with conductor 1.5 mm <sup>2</sup> ) 1.4 ohms
Mounting	On symmetrical DIN rail
Miscellaneous <i>Technology</i> <i>Mains visual indicator</i> <i>Housing</i> <i>Warranty</i>	SMC (surface mounted component) Green LED NORYL 1 year
Dimensions	58 x 105 x 90 mm
Weight	0.360 kg
Cable inlets/outlets	Screw type terminal block
Ingress Protection	IP 30
Operating conditions <i>Ambient temperature</i> <i>Relative humidity</i>	-10°C to +45°C 5% to 95% non-condensed
Noise level	Not significant

## VI. DISPOSAL

Concerning the conservation, of the protection and the improvement of the quality of the environment, as well as for the protection of the health of the persons and the careful and rational use of natural resources, SV 4B has to be the object of a selective collection for the electronic equipments and cannot be scrapped with the normal domestic waste. The user thus has the obligation to separate the SV 4B of the other waste so as to guarantee that it is recycled in a sure way at the environmental level. For more details of the existing sites of collection, contact the local administration or the distributor of this product.

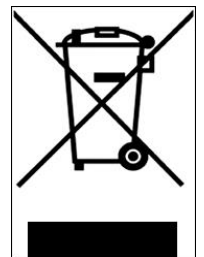

## VII. EU DECLARATION OF CONFORMITY



### DECLARATION UE DE CONFORMITE EU Declaration of Conformity



La société **Oldham S.A.S.**, ZI Est 62000 Arras France, atteste que la  
**Oldham S.A.S.** company, ZI Est 62000 Arras France, declares that the

**Centrale de détection de gaz type Surveyor 4B**  
***Surveyor 4B Gas Controller***

est conforme aux exigences des Directives Européennes suivantes:  
*complies with the requirements of the following European Directives:*

**I) Directive Européenne CEM 2014/30/UE du 26/02/14: Compatibilité Electromagnétique**  
*The European Directive EMC 2014/30/UE dated from 26/02/14: Electromagnetic Compatibility*

Normes harmonisées appliquées: **EN 50270:06** for type 1&2      CEM-Appareils de détection de gaz  
*Harmonised applied Standards*      *EMC-Apparatus for the detection of gases*

**II) Directive Européenne DBT 2014/35/UE du 26/02/14: Basse Tension**  
*The European Directive LVD 2014/35/UE dated from 26/02/14: Low Voltage*

Normes harmonisées appliquées: **EN 61010-1:10**      Règles de sécurité pour appareils  
*Harmonised applied Standard*      électriques de mesurage  
*Safety requirements for electrical  
equipment for measurement*

Arras, le 20/04/2016

Michel Spellemaecker



**Oldham S.A.S.**  
Z.I. EST - C.S. 20417  
62027 ARRAS Cedex – FRANCE  
Tel. : +33 (0)3 21 60 80 80  
www.oldhamgas.com

Global Director of Product Management

UE\_SV\_4B\_rev. A





## **EUROPEAN PLANT AND OFFICES**

Z.I. Est – rue Orfila CS 20417 – 62027 Arras Cedex FRANCE  
Tél: +33 (0)3 21 60 80 80 – Fax: +33 (0)3 21 60 80 00  
Website: <http://www.oldhamgas.com>

AMERICAS  
Tel: +1-713-559-9280  
Fax: +1-281-292-2860  
[americas@oldhamgas.com](mailto:americas@oldhamgas.com)

ASIA PACIFIC  
Tel: +86-21-3127-6373  
Fax: +86-21-3127-6365  
[sales@oldhamgas.com](mailto:sales@oldhamgas.com)

EUROPE  
Tel: +33-321-608-080  
Fax: +33-321-608-000  
[info@oldhamgas.com](mailto:info@oldhamgas.com)