

# EEH110

## Digital humidity and temperature sensor

Well proven humidity sensor element, state-of-the-art ASIC technology and highly accurate humidity and temperature adjustment represent the basis for outstanding performance of the digital humidity and temperature sensor EEH110. The proprietary E+E coating protects the sensor against dirt and corrosion, which leads to excellent long-term stability even in polluted environment. The measured values are available on the digital interfaces I<sup>2</sup>C, PWM and PDM as well as on an analogue voltage output.



### 1. FEATURES

- Multipoint humidity / temperature factory calibration
- Excellent long term stability due to the E+E proprietary coating
- Long standing proven sensor technology
- DFN enclosure 3.6 x 2.8 x 0.75 mm
- 3 digital interfaces: I<sup>2</sup>C, PWM and PDM + analogue humidity voltage output
- Supply voltage 5 V

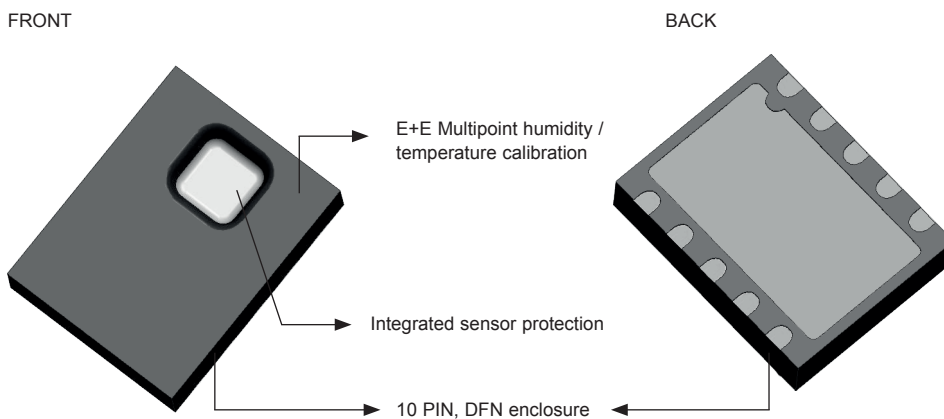

Figure 1: Description

### 2. DIMENSIONS (MM/INCH)

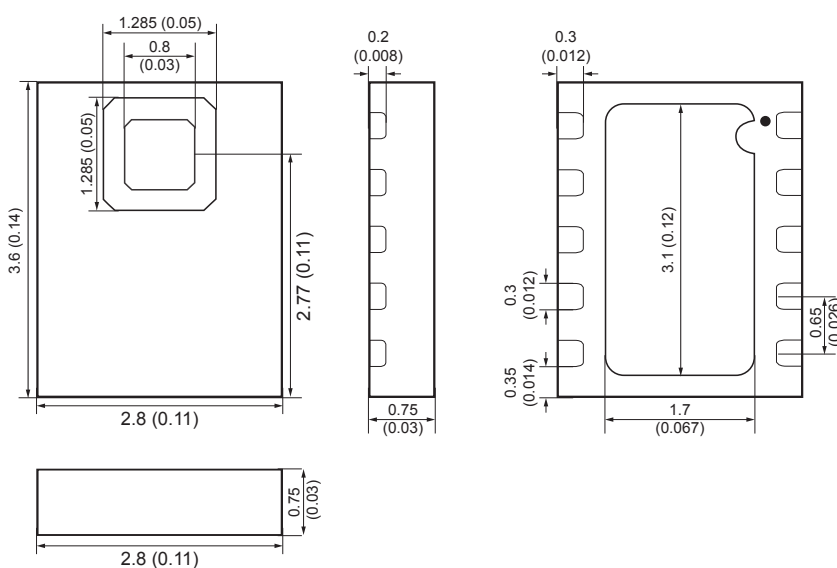

Figure 2: Dimensions

### 3. SENSOR PERFORMANCE

EEH110 is a relative humidity sensor and temperature sensor with band gap circuit, it contains oscillator, A/D convertor, regulator, D/A convertor, NVM, digital processing unit and calibration circuit.

#### 3.1. RELATIVE HUMIDITY SENSOR

PARAMETER	CONDITION	MIN	TYP	MAX	UNITS
Resolution <sup>1)</sup>	12 bit		0.04		% RH
	8 bit		0.7		% RH
Accuracy Tolerance <sup>2)</sup>	typ		±2.0		% RH
Repeatability	12 bit		±0.1		% RH
Hysteresis			±1		% RH
Response Time <sup>3)</sup>				10	sec
Operating Range	extended <sup>4)</sup>	0		100	% RH
Long Term Drift <sup>5)</sup>			0.5		% RH/yr

Table 1: Relative Humidity Sensor

1. Default resolution is 14 bit (temperature) / 12 bit (humidity). It can be reduced to 12/8 bit, 11/11 bit or 13/10 bit by command.
2. Accuracies are tested at Outgoing Quality Control at 25 °C and 5.0 V. Values exclude hysteresis and long term drift and are applicable to non-condensing environments only.
3. Time for achieving 63 % of a step function, valid at 25 °C and 1m/s airflow.
4. Standard operating range: 0-80 % RH, beyond this limit sensor may read a reversible offset with slow kinetics (+3 % RH after 60h at humidity >80 % RH).
5. Value may be higher in environments with vaporized solvents, out-gassing tapes, adhesives, packaging materials, etc. For more details please refer to Handling Instructions.

Δ RH(%RH)

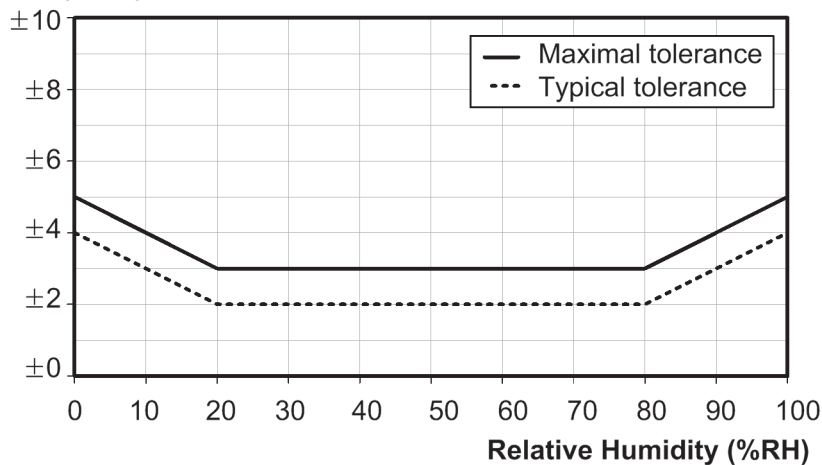

Figure 3: Typical and maximal tolerance at 25 °C for relative humidity.

#### 3.2. TEMPERATURE SENSOR

PARAMETER	CONDITION	MIN	TYP	MAX	UNITS
Resolution <sup>1)</sup>	14 bit		0.01		°C
	12 bit		0.04		°C
Accuracy Tolerance	14 bit		±0.3		°C
Repeatability	12 bit		±0.1		°C
Response Time <sup>2)</sup>				30(TBD)	sec
Operating Range	extended <sup>3)</sup>	-40		125	°C
Long Term Drift			0.05		°C/yr

Table 2: Temperature Sensor

1. Default resolution is 14 bit (temperature) / 12 bit (humidity). It can be reduced to 12/8 bit, 11/11 bit or 13/10 bit by command.
2. Response time depends on heat conductivity of sensor substrate.
3. Standard operating range: -30 ~ +85 °C, exposure to beyond this normal operating range for extended periods may affect the device reliability.

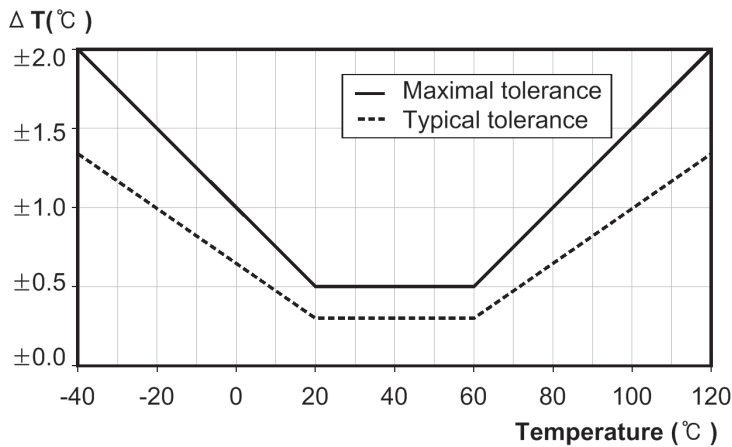

Figure 4: Typical and maximal tolerance for temperature

### 3.3. OPERATING RANGE

The standard working range with regard to the humidity / temperature limits is shown by the dark gray area in Figure 5. The relative humidity signal may offset temporarily as a result of continuous exposure to conditions outside the dark gray region, especially at humidity > 80 % RH. If the sensor is brought back to the standard working range, the initial values will recover. Applications with high humidity at high temperatures will result in slower recovery. Reconditioning procedures (see 8.5) can accelerate this process. Although the sensors would not fail beyond standard working range limits, the specification is guaranteed within the standard working range only.

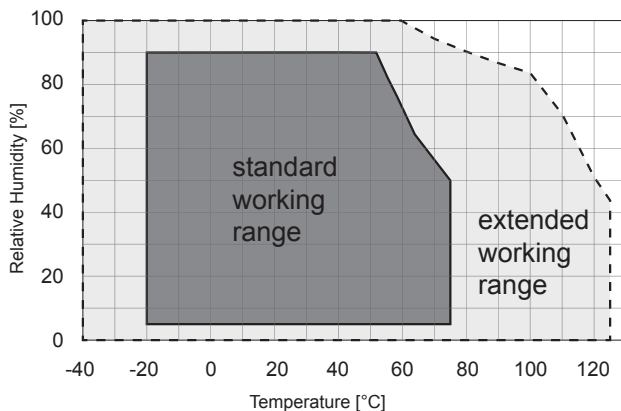

Figure 5: Working range

## 4. ELECTRICAL CHARACTERISTICS

### 4.1. ABSOLUTE MAXIMUM RATINGS

The absolute maximum ratings as given in Table 3 are stress ratings only and give additional information. Functional operation of the device at these conditions is not implied. Exposure to absolute maximum rating conditions for extended periods may affect the device reliability (e.g. hot carrier degradation, oxide breakdown).

SYMBOL	PARAMETER	MIN	MAX	UNIT
VCC	Power Supply	-0.3	6	V
VLOGIC	Digital I/O Pins (SDA, SCL, SEL[1:0] )	-0.3	VCC + 0.3	V
VANALOG	Analog Output Pins (HTOUT)	-0.3	VCC + 0.3	V
I <sub>IN</sub>	Input Current on any Pin	-100	100	mA
T <sub>STG</sub>	Storage Temperature	-55	150	°C
T <sub>OP</sub>	Operation Temperature	-40	125	°C

Table 3: Absolute maximum ratings

## 4.2. ELECTRICAL SPECIFICATION

The electrical characteristics such as power consumption, low and high level input and output voltages depend on the supply voltage. For proper communication with the sensor it is essential to make sure that signal design is strictly within the limits given in Table 4, Table 5 and Figure 6.

PARAMETER	CONDITION	MIN	TYP	MAX	UNITS
Supply Voltage	VCC	4.5	5.0	5.25	V
Current Dissipation	Sleep		65		uA
	Measuring, SEL[1:0]=11		270		uA
	Average 8 bit, SEL[1:0]=11		68		uA
	HTOUT enable, SEL[1:0]=00		300		uA
PWM Freq.	SEL[1:0]=01		120		Hz
Measure Freq.	SEL[1:0]=00,01		2		Hz
Driving Load	HTOUT, Capacitive Load	-	-	10	uF
	HTOUT, Resistive Load	1K	-	-	Ω
Communication	Digital 2-wire interface, I <sup>2</sup> C, SEL[1:0]				

**Table 4:** DC characteristics of digital input/output pads. VCC = 5 V, T = 25 °C, unless otherwise noted.

PARAMETER	CONDITION	MIN	TYP	MAX	UNITS
Output Low Voltage, VOL		0	-	0.4	V
Output High Voltage, VOH		VCC X 0.7	-	VCC	V
Input Low Voltage, VIL		0	-	VCC X 0.3	V
Input High Voltage, VIH		VCC X 0.7	-	VCC	V
SCL Frequency, fSCL		0	-	0.4	MHz
SCL High Time, tSCLH		0.6	-	-	μs
SCL Low Time, tSCLL		1.3	-	-	μs
SDA Set-Up Time, tSU		100	-	-	ns
SDA Hold Time, tHD		0	-	900	ns
SDA Valid Time, tVD		0	-	400	ns
SCL/SDA Fall Time, tF		0	-	100	ns
SCL/SDA Rise Time, tR		0	-	300	ns
Capacitive Load on Bus Line		0	-	400	pF

**Table 5:** Timing specifications of digital input/output pads for I<sup>2</sup>C fast mode. Entities are displayed in Figure 4. VCC = 5 V, T = 25 °C, unless otherwise noted.

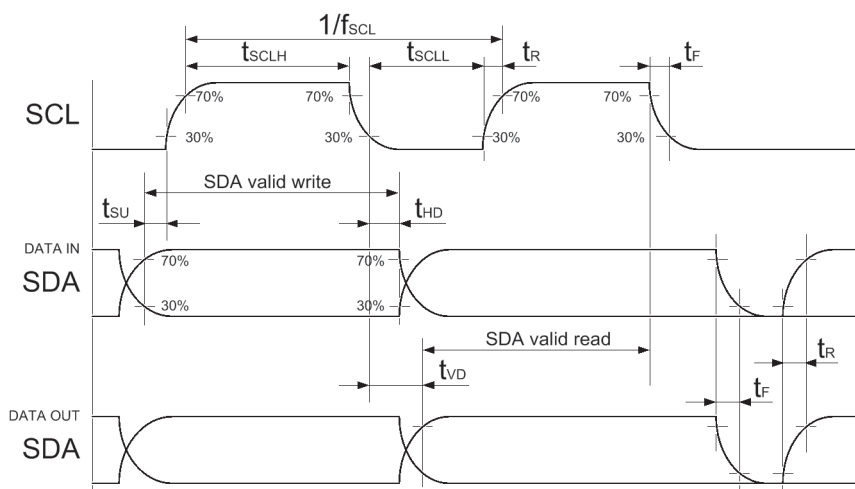

**Figure 6:** Timing Diagram for Digital Input / Output Pads, abbreviations are explained in Table 5. SDA directions are seen from the sensor. Bold SDA line is controlled by the sensor, plain SDA line is controlled by the micro-controller. Note that SDA valid read time is triggered by falling edge of anterior toggle.

## 5. INTERFACE

### 5.1. PIN CONFIGURATION

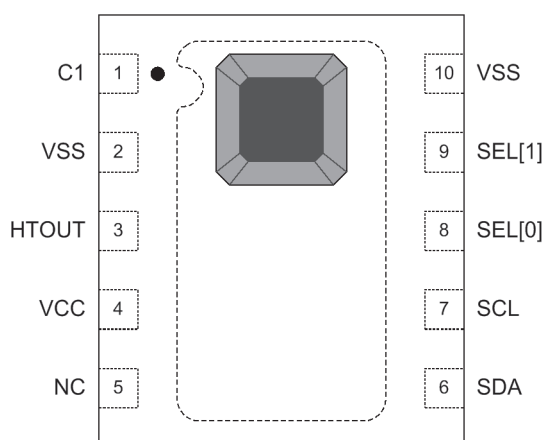

Figure 7: Pin Assignment (Through View): DFN-10 3.6 x 2.8

### 5.2. PIN DESCRIPTION

NAME	PIN#	TYPE	DESCRIPTION
C1	1	I/O	Capacitor Connection Pin for Regulated Voltage. Recommended capacitance is 1 uF / 6.3 V
VSS	2	G	Ground
HTOUT	3	O	Humidity Voltage Output
VCC	4	P	VCC Power Supply
NC	5	NC	No connection
SDA	6	I/O	I <sup>2</sup> C mode: serial data signal PWM/PDM mode: PWM/PDM Output Analog mode: VCC or VSS level connection
SCL	7	I/O	I <sup>2</sup> C mode: serial data signal PWM/PDM mode: Humidity/Temperature Selection Analog mode: VCC level connection
SEL[0]	8	I	Mode Selection
SEL[1]	9	I	Mode Selection
VSS	10	G	Ground
EP			Exposed Pad. EP is electrically connected to GND

Table 6: Pin description table

### 5.3. POWER PINS (VCC, VSS)

The recommended supply voltage of EEH110 is 5.0 V. Supply Voltage (VCC) and Ground (VSS) must be decoupled with a 100 nF capacitor, placed as close as possible to the sensor.

### 5.4. SERIAL CLOCK, SCL

SCL is used to synchronize the communication between microcontroller (MCU) and the sensor. Since the interface consists of fully static logic there is no minimum SCL frequency.

### 5.5. SERIAL DATA & BIT STREAM, SDA

The SDA port is used as two purposes according to the SEL[1:0] pin setting. The first is as I<sup>2</sup>C interface data port and the second is usage as PWM/PDM output port.

On SDA the sensor is providing PWM/PDM output. The signal is carrying humidity or temperature data depending on SEL[1:0] setting.

When EEH110 is used at I<sup>2</sup>C interface mode, the SDA pin is used to transfer data in and out of the sensor. For sending a command to the sensor, SDA is valid on the rising edge of SCL and must remain stable while SCL is high. After the falling edge of SCL the SDA value may be changed. For safe communication SDA shall be valid t<sub>SU</sub> and t<sub>HD</sub> before the rising and after the falling edge of SCL, respectively – see Figure 4. For reading data from the sensor, SDA is valid t<sub>VD</sub> after SCL has gone low and remains valid until the next falling edge of SCL.

To avoid signal contention the micro-controller unit (MCU) must only drive SDA and SCL low. External pull-up resistors (e.g. 10 kΩ), are required to pull the signal high. For the choice of resistor size please take bus capacity requirements into account (compare Table 5). It should be noted that pull-up resistors may be included in I/O circuits of MCUs. See Table 4 and Table 5 for detailed I/O characteristic of the sensor.

SEL[1:0]	LOGIC		ANALOG
	SCL	SDA	HTOUT
00	1	0 or 1	RH
01	0	PWM - T	NA
01	1	PWM - RH	NA
10	0	PDM - T	NA
10	1	PDM - RH	NA
11	Controlled by I <sup>2</sup> C		NA

Table 7: SEL[1:0] pin setting condition table

The SDA and SCL pins are set as 'L' or 'H' when the analogue output ports are used.

The SCL pin has to be fixed as 'L' or 'H' under PWM/PDM mode and leave the analogue output ports, HTOUT as floating.

## 5.6. STARTUP SENSOR

As a first step, the sensor is powered up to the chosen supply voltage VCC (typical 5.0 V). After power-up, the sensor needs at most 10 ms, while SCL is high, for reaching idle state, i.e. to be ready accepting commands from the master (MCU) or the sensor starts measuring and providing data on PWM bit-stream. If EEH110 is under Analogue mode, analogue voltage output will provide the data on analogue mode.

Whenever the sensor is powered up, but not performing a measurement or communicating, it is automatically in idle state (sleep mode).

## 6. COMMUNICATION BY I<sup>2</sup>C PROTOCOL WITH SENSOR

### 6.1. START / STOP SEQUENCE ON I<sup>2</sup>C

I<sup>2</sup>C communication can be initiated by sending a START condition from the master, a high-to-low transition on the SDA line while the SCL is high. A Stop condition, a low-to-high transition on the SDA line while the SCL input is high, is sent by the master (see Figure 8).

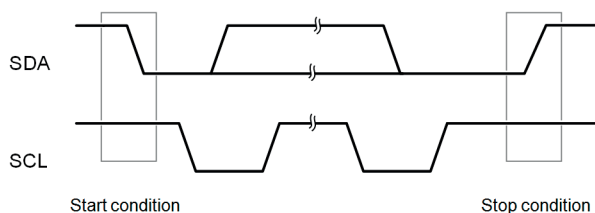

Figure 8: Definition of I<sup>2</sup>C Start and Stop Conditions

### 6.2. SENDING A COMMAND

After sending the Start condition, the subsequent I<sup>2</sup>C header consists of the 7 bit I<sup>2</sup>C device address '1000000' and an SDA direction bit (Read R: '1', Write W: '0'). The sensor indicates the proper reception of a byte by pulling the SDA pin low (ACK bit) after the falling edge of the 8th SCL clock.

After the issue of a measurement command ('11100011' for temperature, '11100101' for relative humidity), the MCU must wait for the measurement to complete. The basic commands are summarized in Table 8.

COMMAND	COMMENT	CODE
Trigger T measurement	hold master	11100011
Trigger RH measurement	hold master	11100101
Trigger T measurement	no hold master	11110011
Trigger RH measurement	no hold master	11110101
Write User Register		11100110
Read User Register		11100111
Soft Reset		11111110

Table 8: Basic command set, RH stands for relative humidity, and T stands for temperature.

### 6.3. HOLD / NO HOLD MASTER MODE

There are two different operation modes to communicate with the sensor: Hold Master mode or No Hold Master mode. In the first case the SCL line is blocked (controlled by sensor) during measurement process while in the latter case the SCL line remains open for other communication while the sensor is processing the measurement.

No hold master mode allows for processing other I<sup>2</sup>C communication tasks on a bus while the sensor is measuring. A communication sequence of the two modes is displayed in Figure 9 and Figure 10, respectively.

In the hold master mode, the EEH110 pulls down the SCL line while measuring to force the master into a wait state. By releasing the SCL line the sensor indicates that internal processing is terminated and that transmission may be continued.

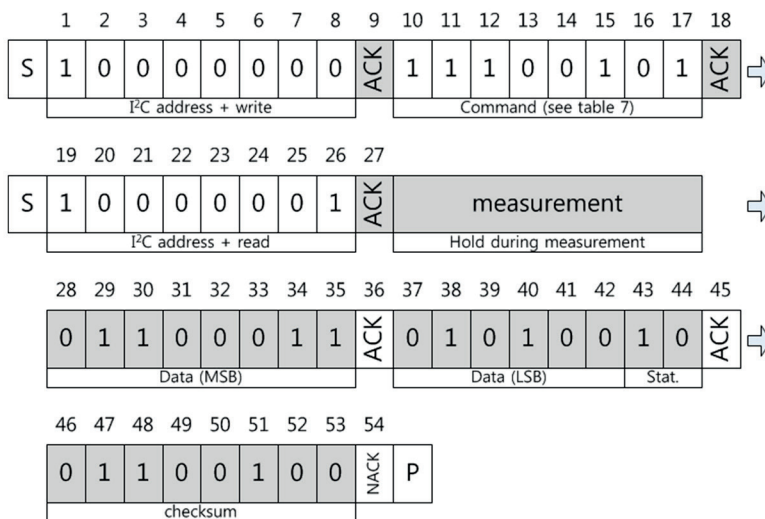

Figure 9: Hold master communication sequence – grey blocks are controlled by EEH110. Bit 45 may be changed to NACK followed by Stop condition (P) to omit checksum transmission.

In no hold master mode, the MCU has to poll for the termination of the internal processing of the sensor. This is done by sending a Start condition followed by the I<sup>2</sup>C header (1000001) as shown in Figure 10.

If the internal processing is finished, the sensor acknowledges the poll of the MCU and data can be read by the MCU. If the measurement processing is not finished the sensor answers no ACK bit and the Start condition must be issued once more.

For both modes, since the maximum resolution of a measurement is 14 bit, the two last least significant bits (LSBs, bits 43 and 44) are used for transmitting status information. Bit 1 of the two LSBs indicates the measurement type ('0':temperature, '1':humidity). Bit 0 is currently not assigned.

In the examples given in Figure 9 and Figure 10 the sensor output is DRH = '0110'0011'0101'0000'. For the calculation of physical values Status Bits must be set to '0' – see Chapter 5.

The maximum duration for measurements depends on the type of measurement and resolution chosen – values are displayed in Table 9. Maximum values shall be chosen for the communication planning of the MCU.

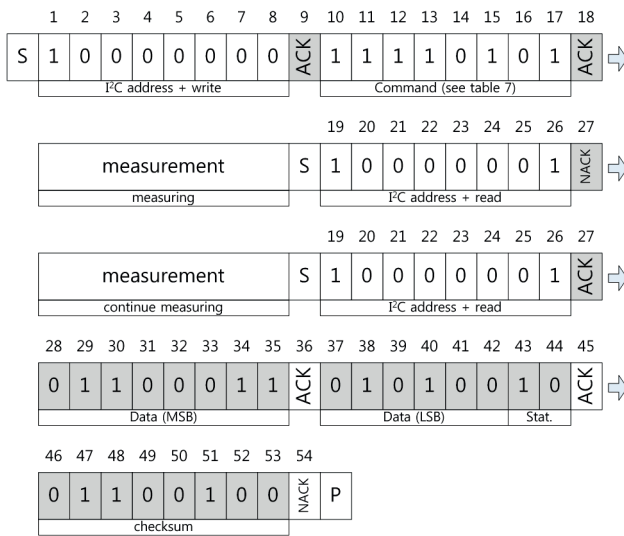

**Figure 10:** No Hold master communication sequence – grey blocks are controlled by EEH110. If measurement is not completed upon “read” command, sensor does not provide ACK on bit 27 (more of these iterations are possible). If bit 45 is changed to NACK followed by Stop condition (P) checksum transmission is omitted.

RESOLUTION	RH (TYP)	T (TYP)	UNITS
14 bit		34	ms
13 bit		17	ms
12 Bit	38	17	ms
11 bit	22	9	ms
10 bit	22		ms
8 bit	9		ms

**Table 9:** Measurement times for RH and T measurements at different resolutions

Please note: I<sup>2</sup>C communication allows for repeated Start conditions (S) without closing prior sequence with Stop condition (P) – compare Figures 9, 10 and 12. Still, any sequence with adjacent Start condition may alternatively be closed with a Stop condition.

### 6.4. SOFT RESET

This command (see Table 8) is used for rebooting the sensor system without switching the power off and on again. Upon reception of this command, the sensor system reinitializes and starts operation according to the default settings – with the exception of the heater bit in the user register (see Sect. 6.3). The soft reset takes less than 15 ms.

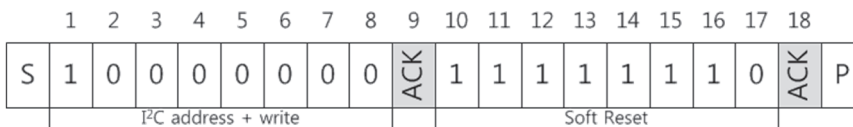

**Figure 11:** Soft Reset – grey blocks are controlled by EEH110.

### 6.5. USER REGISTER

The content of User Register is described in Table 10. Please note that reserved bits must not be changed and default values of respective reserved bits may change over time without prior notice. Therefore, for any writing to the User Register, default values of reserved bits must be read first. Thereafter, the full User Register string is composed of respective default values of reserved bits and the remainder of accessible bits optionally with default or non-default values. OTP Reload is a safety feature and loads the entire OTP settings to the register before every measurement. This feature is disabled per default and is not recommended for use. Please use Soft Reset instead – it contains OTP Reload.



BIT	#BITS	DESCRIPTION / CODING	DEFAULT		
7,0	2	Measurement resolution		00	
			RH		Temp
		00	12 bit		14 bit
		01	8 bit		12 bit
		10	10 bit		13 bit
		11	11 bit	11 bit	
6,5,4,3	4	Reserved		0111	
2	1	Reserved		0	
1	1	Disable OTP reload		1	

**Table 10:** User Register. Reserved bits must not be changed. "OTP reload" = '0' loads default settings after each time a measurement command is issued.

An example for I<sup>2</sup>C communication reading and writing the User Register is given in Figure 12.

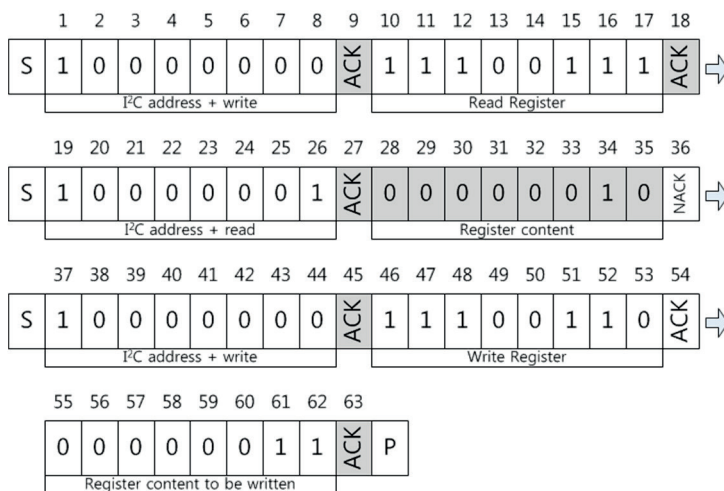

**Figure 12:** Read and write register sequence – grey blocks are controlled by EEH110. In this example, the resolution is set to 8 bit / 12 bit.

## 6.6. CRC CHECKSUM

The EEH110 provides a CRC-8 checksum for error detection. The polynomial used is  $x^8 + x^5 + x^4 + 1$ .

## 6.7. CONVERSION OF SIGNAL OUTPUT

Default resolution is set to 12 bit relative humidity and 14 bit temperature reading.

Measured data are transferred in two byte packages, i.e. in frames of 8 bit length where the most significant bit (MSB) is transferred first (left aligned).

Each byte is followed by an acknowledge bit. The two status bits, the last bits of LSB, must be set to '0' before calculating physical values.

In the example of Figure 9 and Figure 10, the transferred 16 bit relative humidity data is '0110001101010000' = 25424.

### Relative Humidity Conversion

With the relative humidity data output  $D_{RH}$  the relative humidity RH is obtained by the following formula (result in % RH), no matter which resolution is chosen:

$$RH = -6 + 125 \cdot \frac{D_{RH}}{2^{16}}$$

In the example given in Figure 9 and Figure 10 the relative humidity results to be 42.5 % RH.

$$RH = -6 + 125 \cdot \frac{25424}{65536} = 42.492 \approx 42.5$$

The physical value RH given above corresponds to the relative humidity above liquid water according to World Meteorological Organization (WMO). For relative humidity above ice RH<sub>i</sub> the values need to be transformed from relative humidity above water RH<sub>w</sub> at temperature t. The equation is given in the following formular:

$$RH_i = RH_w \cdot \exp\left(\frac{\beta_w \cdot t}{\lambda_w + t}\right) / \exp\left(\frac{\beta_i \cdot t}{\lambda_i + t}\right)$$

Units are % RH for relative humidity and °C for temperature. The corresponding coefficients are defined as follows:  $\beta_w = 17.62$ ,  $\lambda_w = 243.12$  °C,  $\beta_i = 22.46$ ,  $\lambda_i = 272.62$  °C.

### Temperature Conversion

The temperature T is calculated by inserting temperature data output D<sub>T</sub> into the following formula (result in °C), no matter which resolution is chosen:

$$T = -46.85 + 175.72 \cdot \frac{D_T}{2^{16}}$$

## 7. STAND-ALONE RELATIVE HUMIDITY OUTPUT

### 7.1. ANALOGUE OUTPUT

EEH110 support direct analogue output of relative humidity. By setting SEL[1:0] as '00', analogue output is selected. SCL level setting '1' for humidity output mode is possible. The sensor measures twice per second. Output resolution of RH is set to 10 bit.

#### Conversion of Signal Output

The sensor reading is linear and hence it can be converted to a physical value by an easy linear equation.

With the relative humidity signal output the relative humidity RH is obtained by the following formula (result in % RH):

$$V_{HOUT} \text{ (mV)} = 26.23 \cdot \text{RH (\%)} + 1032$$

$$\text{RH(\%)} = \frac{1}{26.23} \cdot (-1032 + V_{HOUT} \text{ (mV)})$$

The physical value RH given above corresponds to the relative humidity above liquid water according to World Meteorological Organization (WMO).

### 7.2. PWM OUTPUT

PWM signal runs on a base frequency of 120 Hz, the data signal is provided on SDA line. By setting SEL[1:0] as '01', the PWM output mode is selected. SCL level setting '1' for humidity and '0' for temperature output mode is possible. The sensor measures twice per second. Output resolution of RH and Temperature are set to 10 bit and 12 bit each.

#### PWM Specification

Pulse Width Modulation runs on a constant frequency and the measured information is provided as duty cycle on that frequency – see Figure 13.

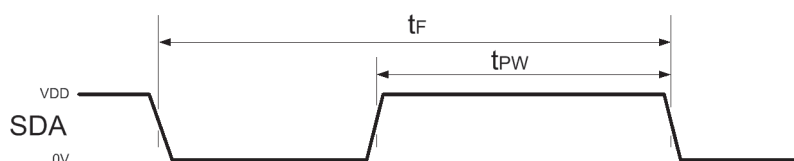

**Figure 13:** PWM signal. Base frequency runs constantly at approximately 120 Hz. hence t<sub>F</sub> is about 8.3 ms. The signal is provided on t<sub>PW</sub> as a ratio of t<sub>F</sub>.

The measured data – either humidity or temperature – is provided as ratio of  $t_{PW}$  and  $t_F$ .  $t_{PW}$  shall always be given as ratio of  $t_F$  to make it independent of variations of the base frequency.

### Conversion of Signal Output

The sensor reading is linear and hence it can be converted to a physical value by an easy linear equation.

With the relative humidity signal output the relative humidity RH is obtained by the following formula (result in % RH):

$$RH = -6 + 125 \cdot \frac{t_{PW}}{t_F}$$

The physical value RH given above corresponds to the relative humidity above liquid water according to World Meteorological Organization (WMO).

The temperature T is calculated by inserting the ratio of  $t_{PW}$  and  $t_F$  into the following formula (result in °C):

$$T = -46.85 + 175.72 \cdot \frac{t_{PW}}{t_F}$$

## 7.3. PDM OUTPUT

PDM signal is a pulse sequence that with a low pass filter may be converted into analogue voltage output. The data signal is provided on SDA line. By setting SEL[1:0] as '10', the PDM output mode is selected. Humidity and temperature output mode is selected by SCL level. The sensor measures twice per second. Output resolution of RH and Temperature are set to 10 bit and 12 bit each.

### PDM output

Pulse Density Modulation is a bit-stream of pulses; the more high pulses the higher the value in the full measurement range – see Figure 14.

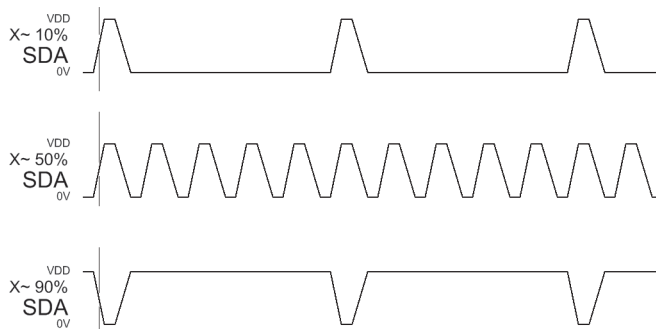

Figure 14: Schematic principle of PDM signal. X represents either RH or T at different levels of sensor output.

### Converting PDM to Analogue Signal

A PDM signal normally is converted to an analogue voltage signal by the addition of a low-pass filter. Figure 15 displays a typical circuit where a simple RC-filter is used.

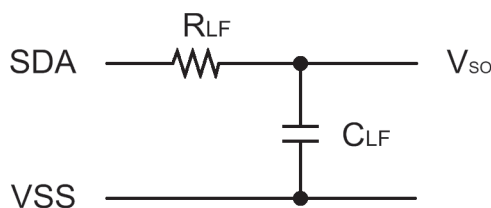

Figure 15: Typical circuit with low pass filter for analog output.

For an acceptable small ripple of the analogue voltage signal, a cut-off frequency of 3.4 Hz is recommended. Typical values for the low pass filter components are R = 100 kΩ and C = 470 nF for humidity mode. The corresponding ripple of the signal is limited to maximal amplitude of ±1 mV for humidity mode. If larger deviations are acceptable the capacitor size can be reduced.

After the low pass filter the sensor provides an output Voltage  $V_{SO}$  which as a portion of  $V_{DD}$  then is converted into a physical value. The sensor reading is linearized and hence it can be converted to a physical value by an easy linear equation.

With the relative humidity signal output the relative humidity RH is obtained by the following formula (result in % RH):

$$RH = -6 + 125 \cdot \frac{V_{SO}}{V_{DD}}$$

The temperature T is calculated by inserting temperature signal output ST into the following formula (result in °C):

$$T = -46.85 + 175.72 \cdot \frac{V_{SO}}{V_{DD}}$$

## 8. APPLICATIONS

### 8.1. STORAGE INSTRUCTION

Moisture Sensitivity Level (MSL) is 1, according to IPC/JEDEC J-STD-020. At the same time, it is recommended to further process the sensors within 1 year after date of delivery.

It is of great importance to understand that a humidity sensor is not a normal electronic component and needs to be handled with care. Chemical vapors at high concentration in combination with long exposure times may offset the sensor reading.

For this reason it is recommended to store the sensors in original packaging including the sealed ESD bag at following conditions: Temperature shall be in the range of 10 °C – 50 °C and humidity at 20 % RH – 60 % RH (sensors that are not stored in ESD bags).

### 8.2. SOLDERING INSTRUCTIONS

For soldering, a lead-free, air-, and nitrogen-reflow-solderable no-clean type 3 solder paste, which meets the requirements of the RoHS Directive 2002/95/EC Art. 4, as well as the standards by J-STD-004, is recommended. Figure 16 shows the typical soldering profile for the soldering paste. The standard reflow soldering ovens may be used which profile given in JEDEC J-STD-020D for Pb -free soldering with a peak temperature of 260°C and a time in the critical zone above (T<sub>peak</sub> - 5 °C) of up to 30 seconds.

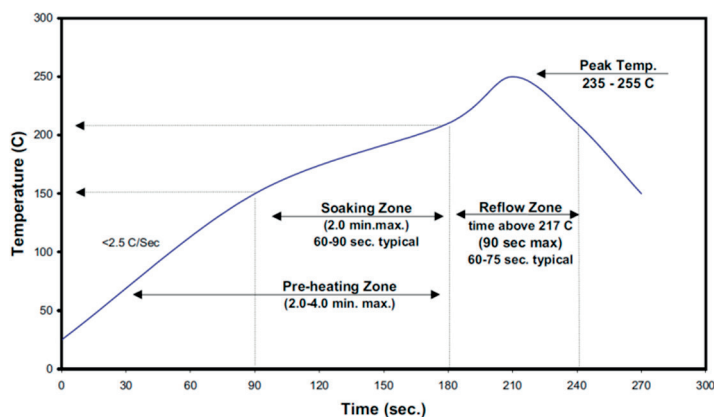

Figure 16: „Typical Lead-free Reflow profile.

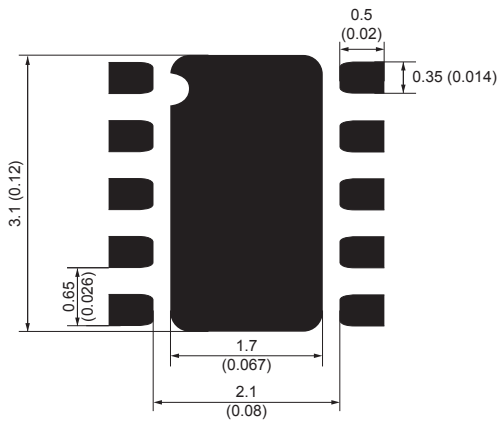

Figure 17: Metal Land pattern

### 8.3. POST REFLOW TREATMENT

We strongly recommend high humidity storage of the boards including the sensor packages after reflow soldering. 8 hours at  $70 \pm 5$  °C,  $75 \pm 5$  % RH or 24 hours at  $80 \pm 10$  % RH (room temperature) is advisable. Calibration or testing should be done after a short further rest (>1 hour) at room conditions.

### 8.4. HANDLING INFORMATION

The critical area for the sensor package is within the open window which contains the active area. It has to be ensured that this area does not come into contact with a handling tool or any other sharp surfaces; any contamination also has to be avoided. During the whole transportation process it should be avoided to expose the sensor to high concentrations of chemical solvents for longer time periods. Otherwise the “Reconditioning procedure (9.5)” must be followed.

### 8.5. RECONDITIONING PROCEDURE

After exposure to extreme conditions or chemical solvents or storage time of several months, the sensor characteristic curve may offset. Exposure to higher temperature will reset the contamination offset (reflow soldering process or e.g.  $110$  °C, 5-7 h). When the parts come back to room temperature a humidity exposure to  $70 \pm 5$  °C,  $75 \pm 5$  % RH for 8 hours completes the reconditioning process.

### 8.6. TEMPERATURE EFFECTS

Relative humidity strongly depends on temperature. Therefore, it is essential to keep humidity sensors at the same temperature as the air of which the relative humidity is to be measured. In case of testing or qualification the reference sensor and test sensor must show equal temperature to allow for comparing humidity readings.

If the sensor shares a PCB with electronic components that produce heat it should be mounted in a way that prevents heat transfer or keeps it as low as possible.

Furthermore, there are self-heating effects in case the measurement frequency is too high. To keep self-heating below  $0.1$  °C, EEH110 should not be active for more than 10 % of the time – e.g. maximum two measurements per second at 12 bit accuracy shall be made.

### 8.7. LIGHT

The EEH110 is not light sensitive but direct exposure to sunshine or strong UV radiation may age the sensor.

### 8.8. FORBIDDEN PACKAGING MATERIALS

Significant concentrations of chemical vapors and long exposure times can influence the characteristic of the sensor. Outgassing of certain packaging materials in a constant volume such as foams (e.g.: Type MOS 2200) glues, adhesive tapes and foils are strictly forbidden and may change the characteristic of the sensor.

## 8.9. WIRING AND SIGNAL INTEGRITY

When this EEH110 is used under I<sup>2</sup>C mode, carrying the SCL and SDA signal parallel and in close proximity (e.g. in wires) for more than 10 cm may result in cross talk and loss of communication. Furthermore, slowing down SCL frequency will possibly improve signal integrity.

Under analogue output modes, the output pin has to be protected from external noise source to get stable output. Power supply pins (VCC,VSS) must be decoupled with a 100 nF capacitor.

## 9. DOCUMENT REVISION HISTORY

DATE	R-PAGE	REVISED CONTENTS	TOTAL PAGE	REV. NO.
11 April 2016	-	Initial release	14	v1.0