

Hepatex PB

For the Separation of Fine Suspended Particles



CLEAN
AIR



POWER
GENERATION



CLEAN
ROOM



INDUSTRIAL

Hepatex PB filters are designed for the separation of fine suspended particles such as bacteria, viruses, soot, dust etc. They are used in supply and exhaust air systems, or in clean room installations in the nuclear, electronic, optical, medical or chemical industries.

Hepatex PB can be combined in a variety of units to suit most applications, particularly where the available space is limited.

Our filters offer long service life thanks to a manufacturing process that ensures high product quality.

The filter medium is tested for penetration, pressure drop, tensile strength, density, weight and water repellency. Each “glass” quality filter is submitted to the oil mist test and is guaranteed leak-free.

KEY FACTS

- Low pressure drop: Reduced energy consumption and operating costs
- Fully-utilised, large filter surface: Extremely long service life
- Optimised air flow: For optimum performance and longer life
- Paper filter medium: No fibre loss
- Inherently stable filter mat: Eliminates dust penetration
- Self-supporting, robust, cellular structure: For rigidity, strength and high burst pressure



Hepatex PB

Hepatex PB

Technical Data

DESIGN, MATERIALS

Hepatex PB are maintenance-free filter cell units, of size 86,5x202x600 mm, consisting of cell frame in galvanised or stainless steel, with cast-in, self-supporting mini-pleated filter media of cellulose, cellulose and glass, or glass fibres.

INSTALLATION

Whenever possible, Hepatex PB should be installed on the pressure side of the system, i.e. between the fan and the distribution duct work.

SEALING THE FILTER CELL

With Silicone or PU mastic or by special adhesive tape. One roll is sufficient for approx. 100 PB filters.

DIMENSIONS (mm)

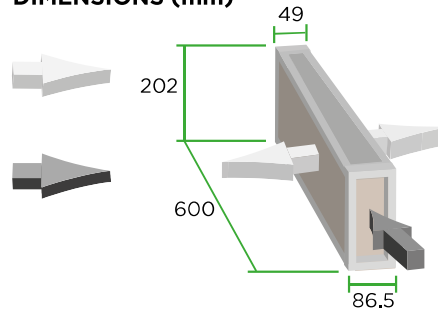

INITIAL PRESSURE DROP

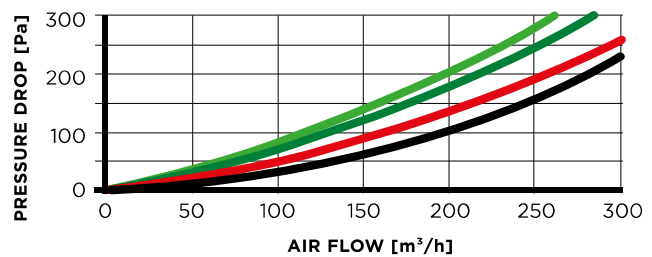

Technical Data	Unit	Cellulose	Cellulose	Cellulose + Glass	Glassfibres
Filter Media	-	Cellulose	Cellulose	Cellulose + Glass	Glassfibres
Active Filter Surface per Cell	approx. m ²	2.8	3.4	3.4	2.8
Weight per Filter Cell	approx. kg	1.2	1.5	1.45	1.25
Rated Air Flow (V _{LN}) per Filter Cell	m ³ /h	200	200	200	200
Rated Air Flow per 610 x 610 mm Module	m ³ /h	4,250	4,250	4,250	4,250
Initial Pressure Drop at V _{LN}	Pa	105	140	180	205
Nominal Final Pressure Drop ¹⁾	Pa	600	600	600	800
Max. Admissible Relative Humidity	%	85	85	85	100
Max. Continuous Temperature	°C	100	100	100	125/220
Filter Class to EN 779/EN 1822	-	F9	E10	E11	H13
Flammability classification to DIN 53438	-	K2/F2	K2/F2	K2/F2	K1/F1
Initial Separation Efficiency					
Sodium Flame Test, EUROVENT 4/4 ²⁾	%	-	92.3	98.6	>99.995
MPPS-DEHS-Test to EN 1822	%	-	>85	>95	>99.97
Efficiency to EN 779 ³⁾	%	>95	-	-	-

1) Recommended final pressure drop approx. 2.5 times the initial pressure drop. 2) GB: B.S. 3928 3) As well as ASHRAE 52.1