

ScandSorb DP

Deep Bed Filter



CLEAN
AIR



POWER
GENERATION



CLEAN
ROOM



INDUSTRIAL

ScandSorb DP is a deep bed gas filter that offers high capacity and security. Contaminated air flows through two 470 mm thick gas filter beds containing activated charcoal or a chemisorbent.

ScandSorb DP is designed for use in demanding industrial applications and is available in either stainless or acid resistant stainless steel. To ensure ease of filter media replacement, ScandSorb features apertures at the top and bottom of the filter and a large sleeve coupling. It is also equipped with jacks for gas measurement during operation.

Providing the ideal solution for high contaminant concentrations, or for when high security is required, ScandSorb DP can be completely customised to suit your exact requirements.

KEY FACTS

- Ensures high safety levels
- Provides high efficiency filtration
- Designed for use in demanding industrial applications
- Simple-to-service



ScandSorb DP Deep Bed Filter

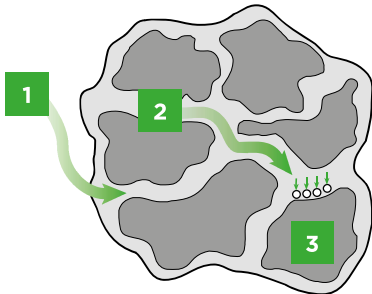

ADSORPTION PRINCIPLE

- 1** Molecule finds its way into the coal particle at the surface.
- 2** The molecule is transported through the macro-pores into the micro-pores, via a process called diffusion.
- 3** Adhesion by Van der Waals force.



ACTIVATED CARBON

Activated carbon is available in a variety of forms such as powders, granules and so-called extruded pellets. Using an entirely natural source substance (such as coconut shells, coal or wood), the raw material is carbonated in the charcoal kiln and then activated with steam at 1,000°C. This high temperature provides a well-developed pore structure – high quality activated carbon has a pore structure of approximately 1,000m²/gram.

To distinguish between different qualities of coal, it is possible to ascertain efficiency by measuring the carbon adsorption capacity with carbon tetrachloride (CTC), for example. A carbon's ability to retain a substance is equal to relationship between the weight of the retained compound and the carbon weight.

DIMENSIONING AND CHOICE

Nominal capacities for activated carbon or chemisorbent filters for comfort air applications are usually measured in m³/s. These filters are typically used to separate temporary occurrences of odour such as automobile exhaust, cigarette smoke, and food etc.

In other applications, such as in heavy and often corrosive industrial environments, a more tailored approach must be adopted, with the exact filter specified according to a variety of factors. Choosing the correct quality and quantity of coal, along with suitable impregnation or chemisorbent, depends on the type of atmospheric gas or vapour, its concentration, the level of treatment required and the desired operating life of the adsorbent.



CHEMISORBENT

An alternative to activated carbon, Chemisorbents consist of round pellets of alumina impregnated with potassium permanganate KMnO₄ – an extremely strong oxidizing agent. In this process, the adsorbed gas or vapour reacts chemically with the sorbent to remove it from the airflow. Chemisorbents can also be used as a catalyst to break down a pollutant so that it can be adsorbed in a subsequent activated charcoal filter.

To determine the contact time (T) of the contaminated air with the sorbent, the following calculation can be employed:

$$T = \frac{\text{m}^3 \text{ adsorbent}}{\text{m}^3/\text{s air}}$$

Contact time can vary considerably depending on the application. From the previous example, comfort air applications can have a contact time as low as 0.05 seconds whilst industrial applications can be as long as 5 seconds. MANN+HUMMEL's expertise in this area can provide you with assistance in making the correct choice of product.

ScandSorb DP Installation

INSTALLATION

ScandSorb DP is delivered empty, with the activated carbon supplied in separate, individual packages. The filter is placed flat on a solid base (the weight of the filter is dependent on size) so that the weight is distributed evenly over the bottom profiles. Connect the filter to the inlet and outlet channels (see Figure 1) and install any monitoring equipment (gas detector, differential pressure gauge, electricity etc).

The coal beds are divided into specialized packets. It is recommended to open a bag at a time and gently bed the content of several packets so that the carbon is evenly distributed. (See Figure below)

Care should be taken when installing the carbon to eliminate the risk of damage to the perforated metal sheet which encloses the coal bed. To ensure that the coal is fully bedded in, a long object (such as a broomstick or similar implement unable to damage to the plate) is used to compact the coal down into the recess. Compact the carbon level to approximately 1 cm below the doors. This is necessary because the air movement will compress the carbon further.

THIS ACTIVITY CAN CREATE DUST - use respiratory protective equipment and eye protection.

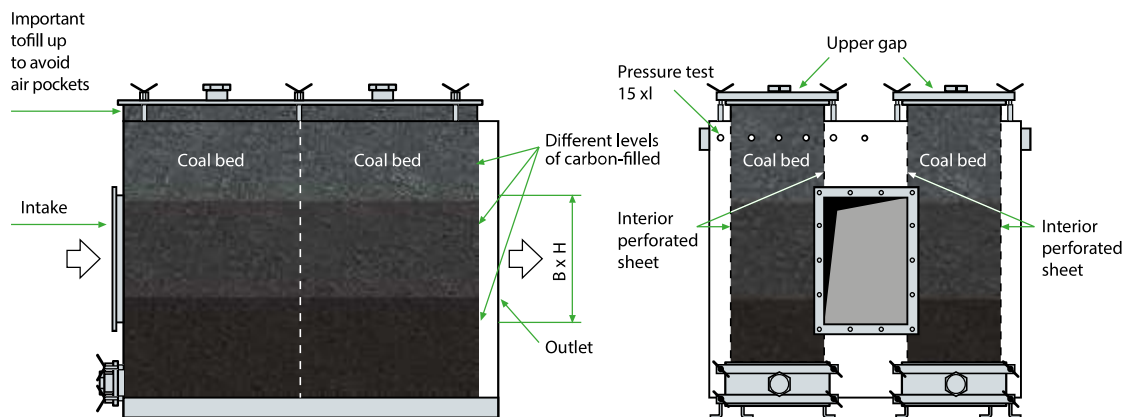

MONITORING OF THE CARBON CONDITION

The coal will continuously adsorb pollutants (gas) from the air stream. Gas molecules bind to the carbon surface until it is saturated. To monitor the level of saturation, ScandSorb DP features a number of test connections (even in the coal bed itself – see Figure 1) where the air can be sampled for its gas composition. Through this gas measurement, an indication of how much of the carbon has been exhausted can be obtained. This provides the necessary information to determine the range of carbon exchange.

REPLACEMENT OF COAL

When emptying the deep bed filter, it is important not to empty a compartment completely when the pressure from the full trays may cause damage to the perforated sheet metal which encloses the coal bed.

There are several ways to empty the filter of the spent activated carbon:

- 1) Suck waste coal via the sleeve coupling present in the upper lids with a suction car or special suction equipment.
- 2) Open the lower lid and rake the coal out.
- 3) Suck out via the sleeve coupling in the lower lid – like 1) above.

Recharging of the new activated carbon should be done as described in "Installation" above.

THIS ACTIVITY CAN CREATE DUST - use respiratory protective equipment and eye protection.

In some cases, the spent carbon is hazardous waste, so special handling, packing, and destruction/disposal procedures must be followed. Contact MANN+HUMMEL for further information. Replacement coal is delivered in bags, large or small, depending on filter size and customer preference.

ScandSorb DP

Technical Data

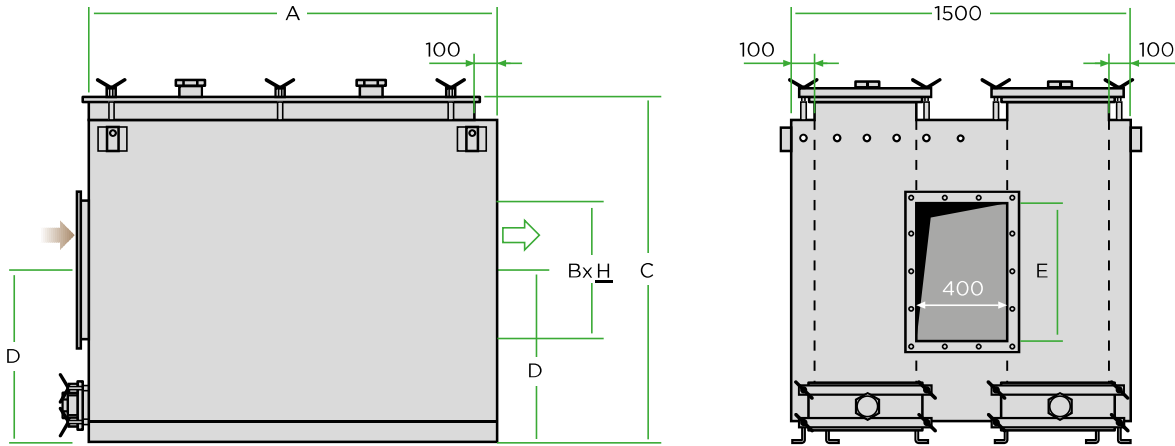

Size	Nominal Flow at 1 sec. Contact Time (m ³ /s)	*) Pressure Drop at Nominal Flow (Pa)	Dimensions				
			A (mm)	B x H (mm)	C (mm)	D (mm)	E (mm)
DP4000	1	600-800	1,100	500 x 500	1,300	750	500
DP8000	2	600-800	1,800	500 x 600	1,500	750	600
DP10000	3	600-800	2,000	600 x 900	2,000	850	900
DP15000	4	600-800	2,650	600 x 900	2,000	1,000	1,200

*) Dependent on choice of media.