



# MODEL DM-500-BR2

## BROMINE SENSOR ASSEMBLY

ISO 9001:2008  
Certified

888-367-4286  
713-559-9200  
fax 281-292-2860  
www.detcon.com  
sales@detcon.com

## SPECIFICATIONS

- Sensor Type**  
Electrochemical Fuel Cell
- Measurement Range**  
0-5 ppm Bromine  
Other ranges available
- Repeatability**  
±2% FS
- Response/Clearing Time**  
T90 <60 seconds
- Span Drift**  
<2% signal loss per month
- Operating Temperature Range**  
-20°C to +50°C; -4°F to +122°F
- Operating Humidity Range**  
15-90% RH non-condensing
- Output**  
Linear 4-20 mA DC
- Input Voltage**  
11.5-28 VDC
- Power Consumption**  
1.6 watts @ 24 VDC
- Electrical Classification**  
Explosion proof  
Class 1, Div. 1, Groups B, C, D
- Ingress Protection**  
NEMA 4X, IP66
- Sensor Life/Warranty**  
Sensor: 2 year warranty  
Transmitter: 2 year warranty
- Safety Approvals**  
CSA/NRTL (US OSHA Certified)

## DIMENSIONS

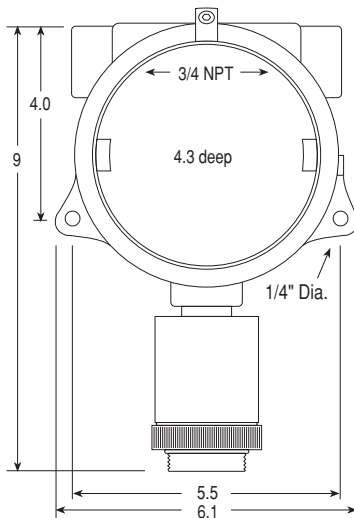

Splashguard 2"H x 2"Dia.

## Electrochemical Fuel Cell

## MicroSafe™ Intelligent Sensor

## DESCRIPTION

Detcon Model DM-500IS-Br2 sensor is designed to detect and monitor Br2 in air over the range 0-5 ppm. The sensor assembly consists of an electrochemical fuel cell mounted in an Intrinsically Safe stainless steel and ABS plastic housing that includes a splashguard with integral cal port, a signal conditioning control transmitter circuit, a base connector board and an explosion proof junction box. The Intrinsically Safe sensor housing design allows direct contact of the target gas to the electrochemical sensor, thus maximizing response time, detectability and repeatability. And because the Intrinsically Safe housing design does not use a stainless steel flame arrestor, it eliminates inaccurate readings due to target gas absorption.

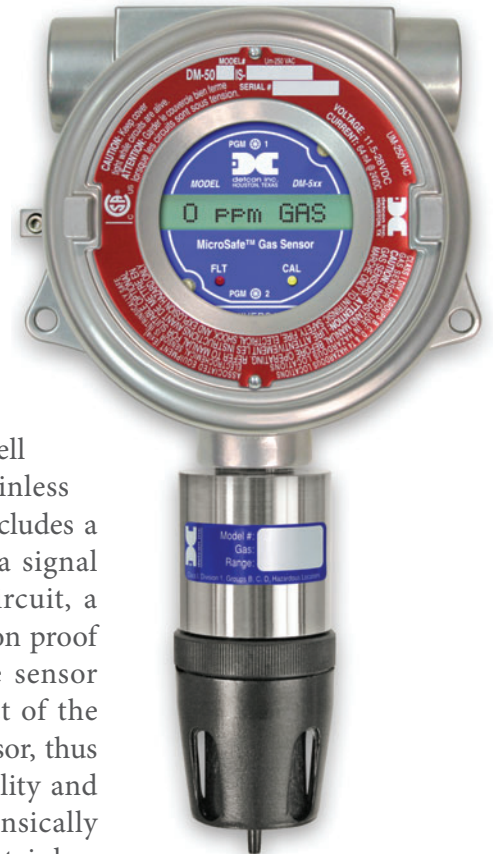

## FEATURES

- ▶ CSA and UL Approved: Class 1, Div. 1, Groups B, C, & D
- ▶ 4-20 mA output
- ▶ Simple menu driven calibration - takes less than 3 minutes
- ▶ Backlit LCD, and LED indicators for Fault, and Cal status
- ▶ Universal plug-in transmitter
- ▶ Intrinsically Safe Sensor Housing
- ▶ Plug-in field-replaceable transmitter
- ▶ Electrochemical plug-in sensor

## ORDER GUIDE

- PN 965-747580-005    DM-500IS-Br2 in Aluminum Junction Box
- PN 965-74758B-005    DM-500IS-Br2 in Stainless Steel Junction Box

[www.detcon.com](http://www.detcon.com)